



International Space Station Paper Model

Assembling User Guide **Part 3:** **OV 105 Endeavour**

October 2000 Version
Flights: 1A/R
STS-88 ISS 01-2A

Model Design: Raimondo Fortezza
Assembly Drawings: Giuseppe De Chiara

NOTE:

This Model is part of the ISS Paper Model. It was built from scratch on the basis of photos published by NASA and using the assembling scheme of another Paper Shuttle Model distributed by BETEVA in scale 1:72 (Raketoplan Space Shuttle Atlantis. Beteva - <http://www.beteva.cz>)

Detailed pictures of Space Shuttles are available at NASA WEB sites. Please check these images before the assembly to control the correct positioning of each part.

Please notify Raimondo Fortezza any error or discrepancy you could find during the assembly. The e-mail address is: fortezza@marscenter.it. The modifications will be implemented according to your suggestions. You will be kept informed when the updated version will be made available.

This model is shareware, and the idea is to develop the model 1:100 of the entire ISS. The Shuttle presented in the next pages is the Endeavour and was the one used to put in orbit Unity. The three models available (Endeavour, Unity and Zarya) can be used to build the "diorama" of STS-88 Shuttle flight.

If you want to support the initiative please send the equivalent of 10 US \$ in your national currency, or even more if you enjoyed in building the model, to the developer at the address reported at page 24. Your name will be posted in the Supporter List published on the Paper-ISS page at MARS WEB site and you can download all the updated version of the ISS with the new Modules that will be launched up to the end of the year 2000.

High-quality printed model is available based on the original un-compressed files and 1440 dpi ink-jet printer. The cost is US \$ 25 or an equivalent value in your currency. Send the money directly via mail to the address indicated at page 12. The model is shipped using ordinary post service. If you want express courier please send an e-mail for a quotation.

OV 105 Endeavour STS-88 Assembling Guide

Cut out and bend the parts following the line. For best results use a sharp hobby knife and a metal straight edge. For some parts a pair of small scissors is better. Glue together the parts using a thin, even coat of ordinary white glue. Print the sheets on a color printer. The format should be compatible with both A-4 or US Letter sheet size. I used an EPSON 750 Color ink-Jet Printer with a resolution of 1440 dpi with excellent results.

Space Shuttle "Endeavour" parts are printed on 12 separate sheets. The sheets marked Glossy should be printed on glossy paper (available for any ink-jet printer). The numbered parts belonging to the sheet are identified by the sheet number followed by the part number.

The Card Board sheets should be printed on cardboard paper (or EPSON Photo Paper) and its parts are identified in the same way

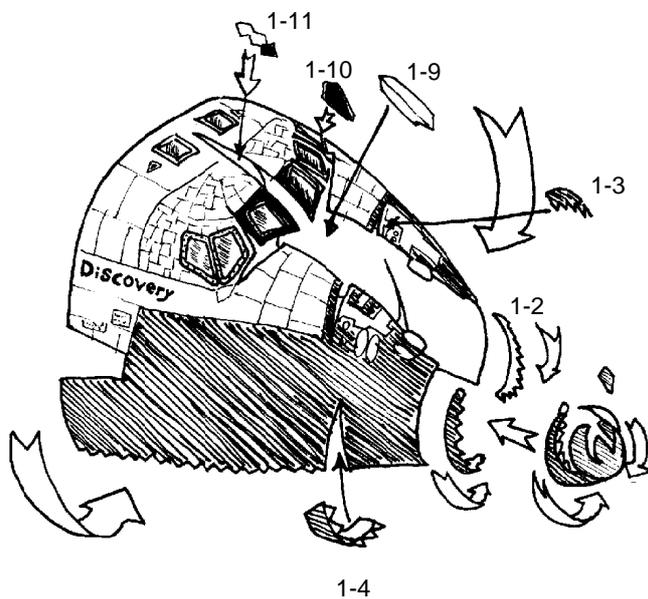

Cut the 1-1 part and all the other pieces up to the number 1-16. Roll the 1-1 on a table edge and, once the shape is similar to the shuttle fore part start to glue all the gluing tabs provided

The parts 1-15 and 1-16 represent the Carbon-carbon nose. Paint the paper edge grey to avoid the white lines. To improve the realism you can cover the paper nose with an homogeneous layer of white glue or filler and paint it grey when dry

Follow the numbering of the gluing tabs indicated in the following drawings

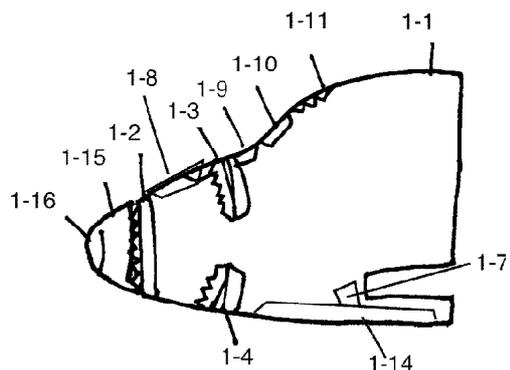
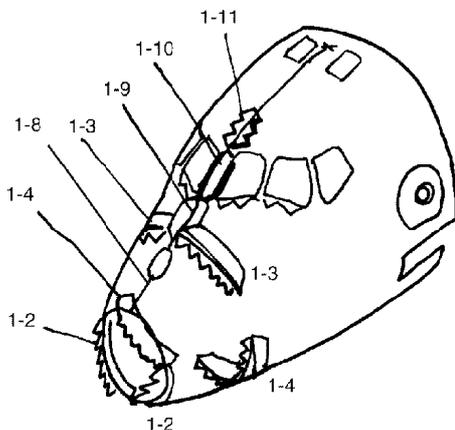
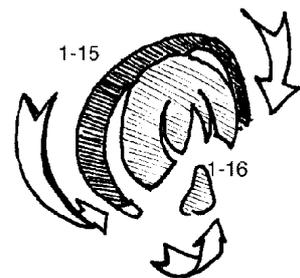



To improve the realism you can cut all the thrusters gray holes and include the nozzles using the parts 1-17 for Vernier thrusters (the small ones) and the 1-18 for the primary thrusters of Reaction Control System. All the nozzles have to be glued inside the part 1-1 with the black side visible through the holes

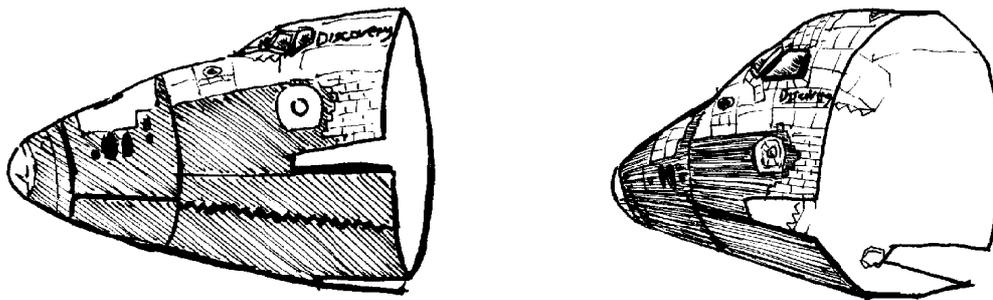

Drawings of the Space Shuttle nose-cockpit area show how it is assembled.

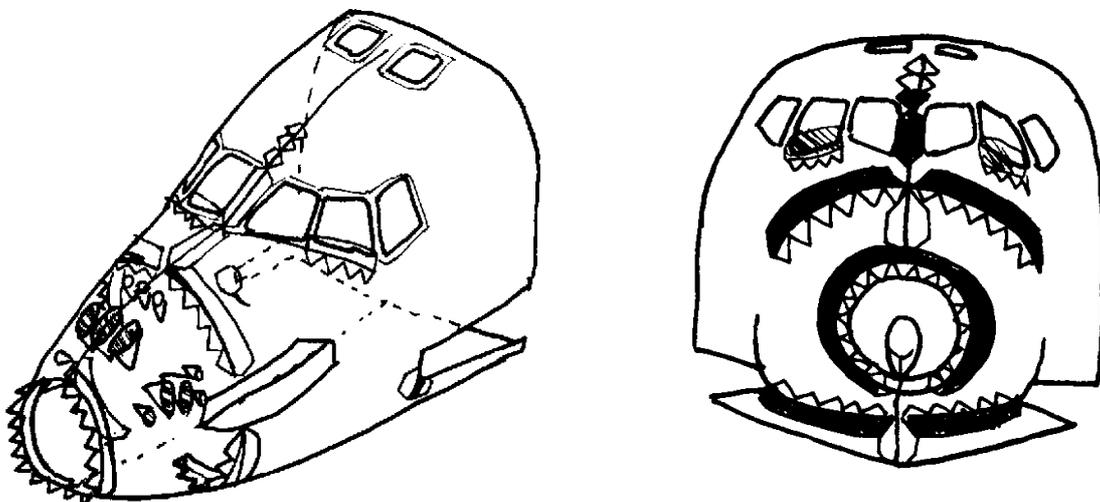

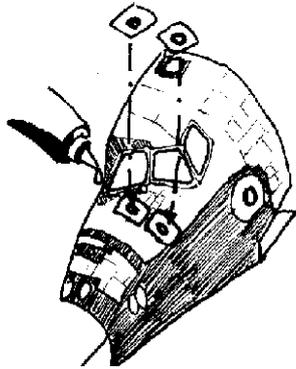

You can also cut the two star-sensors gray holes and gluing the two additional star-sensors 1-12 and 1-13 internally for a more realistic 3-D shape.

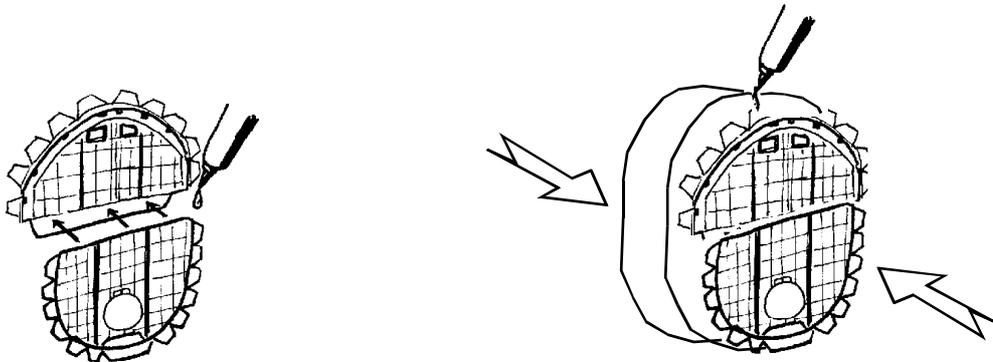

Cut the parts 1-19 and 1-20 and glue them together. To improve the stiffness of this part add two more cardboard layers 1-21 on the back of it (not on the tabs). The reason why the fore cargo wall is divided into two parts is that in the future it will be available also the Shuttle cockpit (upper deck and mid-deck) connected directly with the upper part 1-19. The cockpit will be visible through the transparent window.

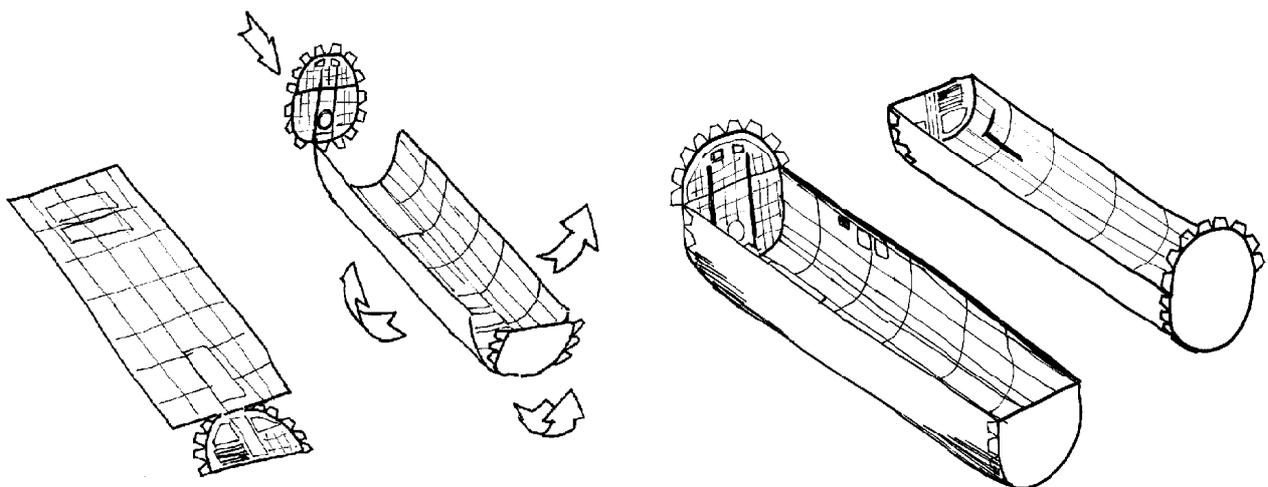

Cut the cargo-bay 3-1. Roll the 3-1 on a table edge and, once the shape is similar to a half pipe, glue the aft wall (the one with flag on it). To improve the stiffness of this part add one more cardboard layer on the back of the flagged wall. The cardboard should not cover the upper part where the back wall is glued with its upper part that is inserted in the Shuttle Motor block. Glue the 1-19/20 to it to form the entire cargo bay.

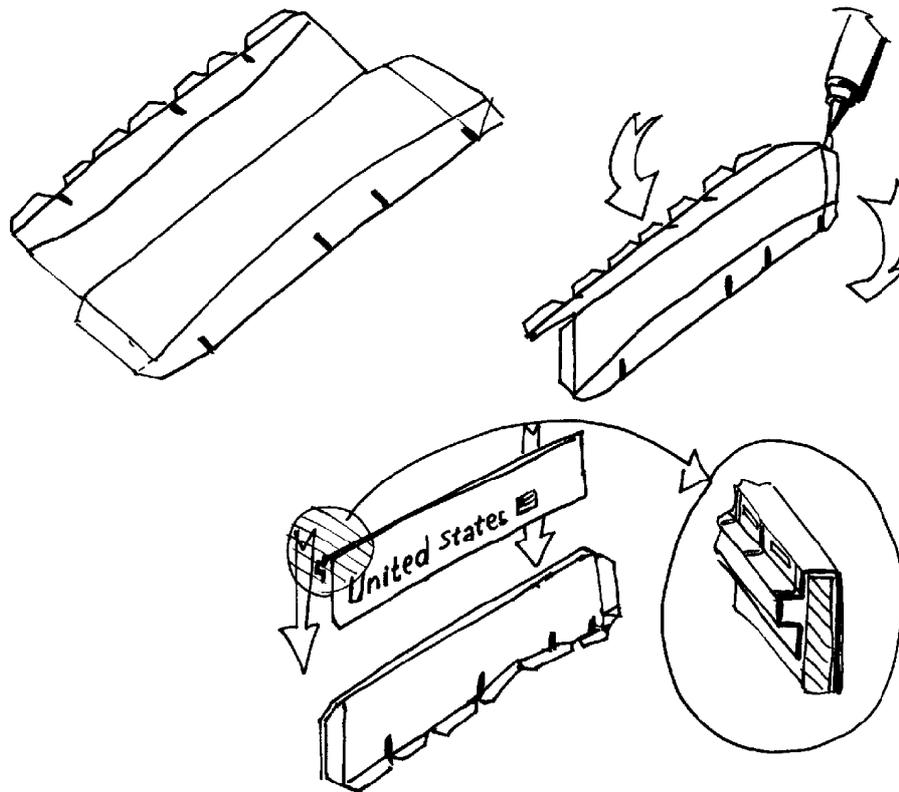

Cut the two 2-1 parts, bend them along the center line and glue them with the painted part external. The gray boxes are the internal wall of the landing gear that at the moment is not included in this kit. Keep the part flats gluing the parts and keeping them under a big book during drying. Cut the two 3-3 and 3-4 parts, bend them as indicated in the above drawing. Use a 1,5 x 1,5 mm strip styrene stick to shape the paper with the illustrated edge. A sharp ruler can also be used for this purpose. The two 3-3 and 3-4 parts have then to be glued on the 2.1 parts with the word “United” that are aligned with the landing gear housing, and 1-20 .

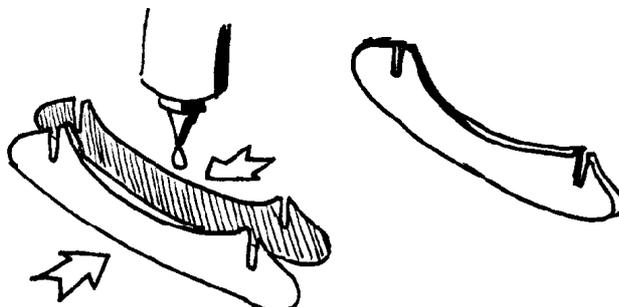

Cut the two 2-2 parts and glue them together. Do the same with 2-3 parts and 3-2 with 4-2 and 4-3 with 4-4. The boxes painted on some of them represent the landing gear housing.

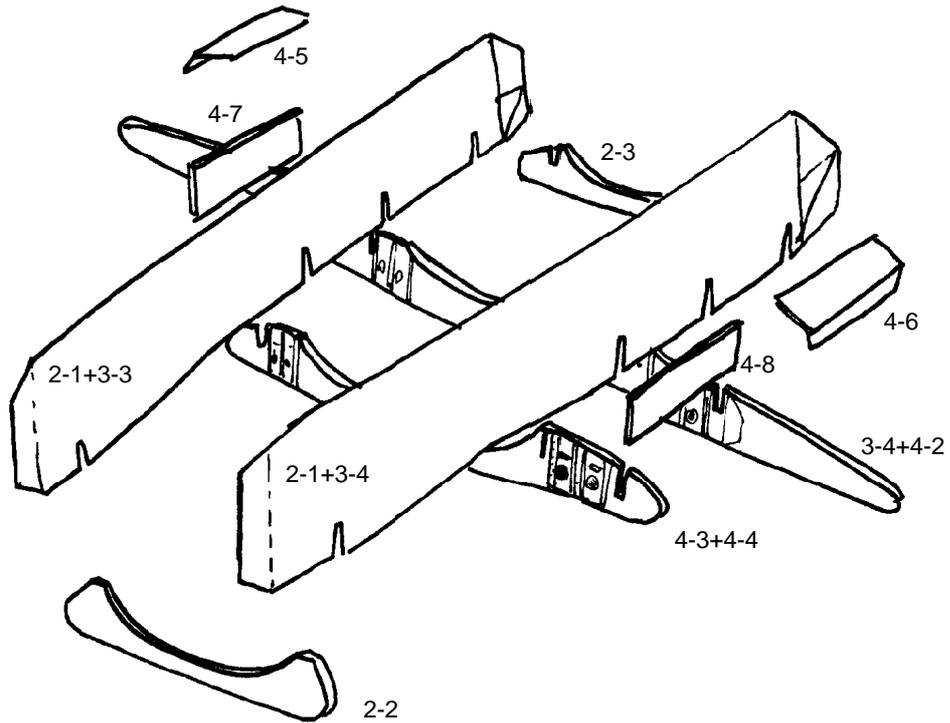

Glue all the parts to form the cargo bay structure. Check the parts before gluing them. The painted parts of the pieces 4-3+4-4, 3-4+4-2, 4-8 and 4-6 should appear as the internal structure of the internal left landing gear housing. Similar is the right housing.

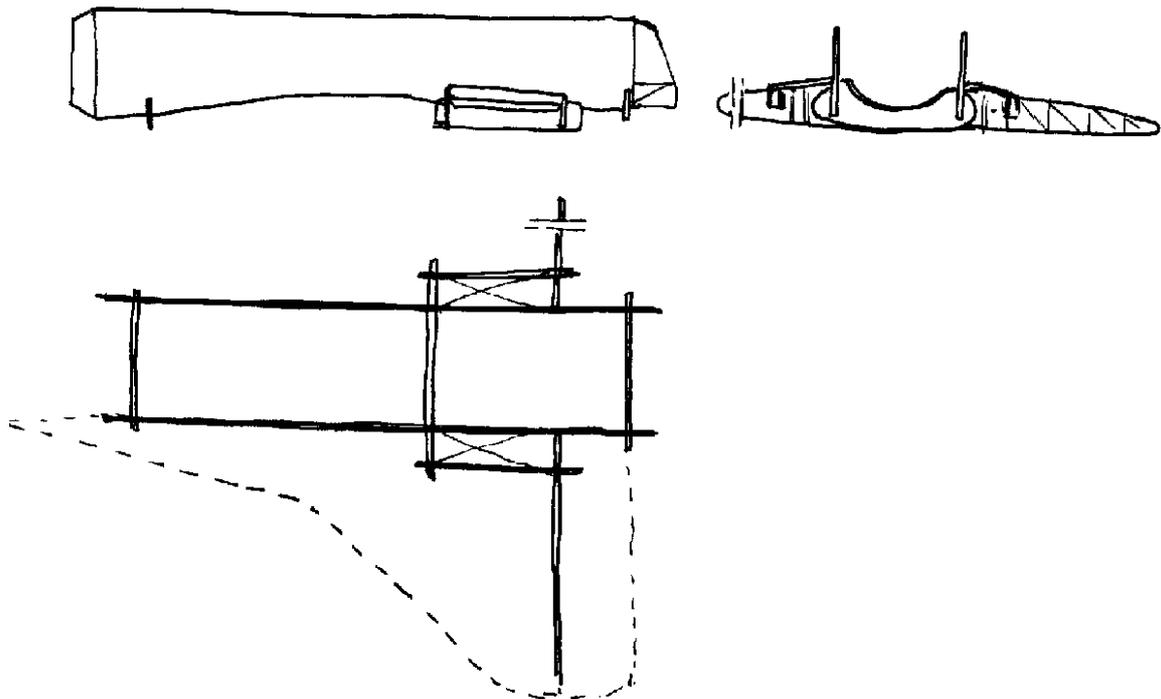

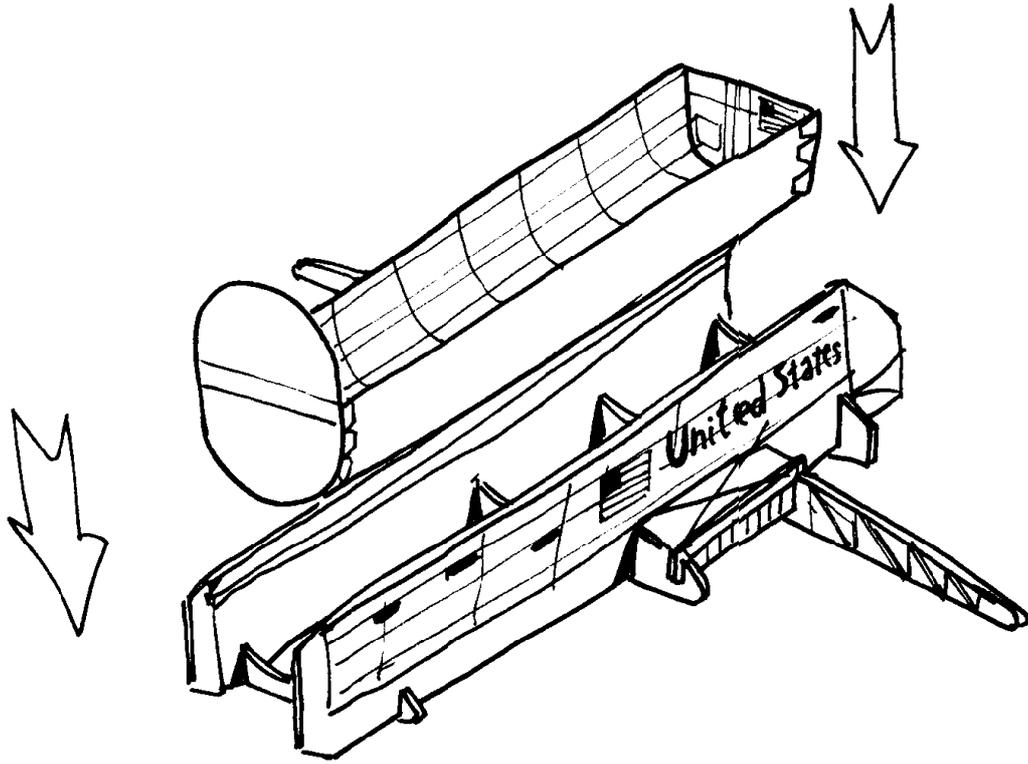

Glue the cargo bay structure with the cargo bay. Try to keep the parts aligned during glue drying.

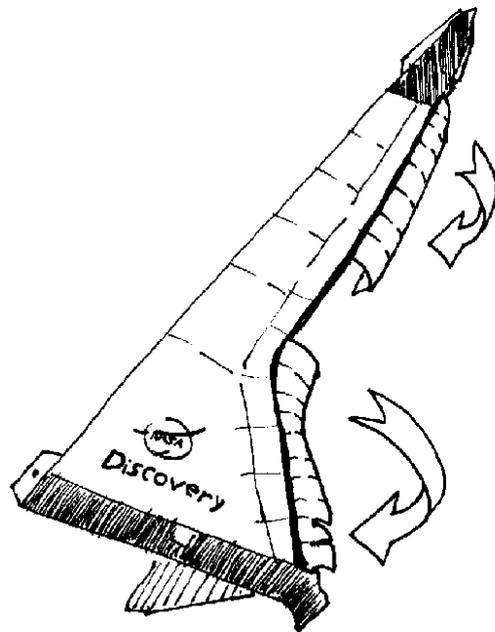

Cut the right wing 6-1 and start to bend it as indicated in the above picture. Try to bend it very smoothly and gently, step by step, avoiding to fold the paper until you reach a sort of U shaped wing with the black tiled part as lower side. Repeat the same procedure with the left wing.

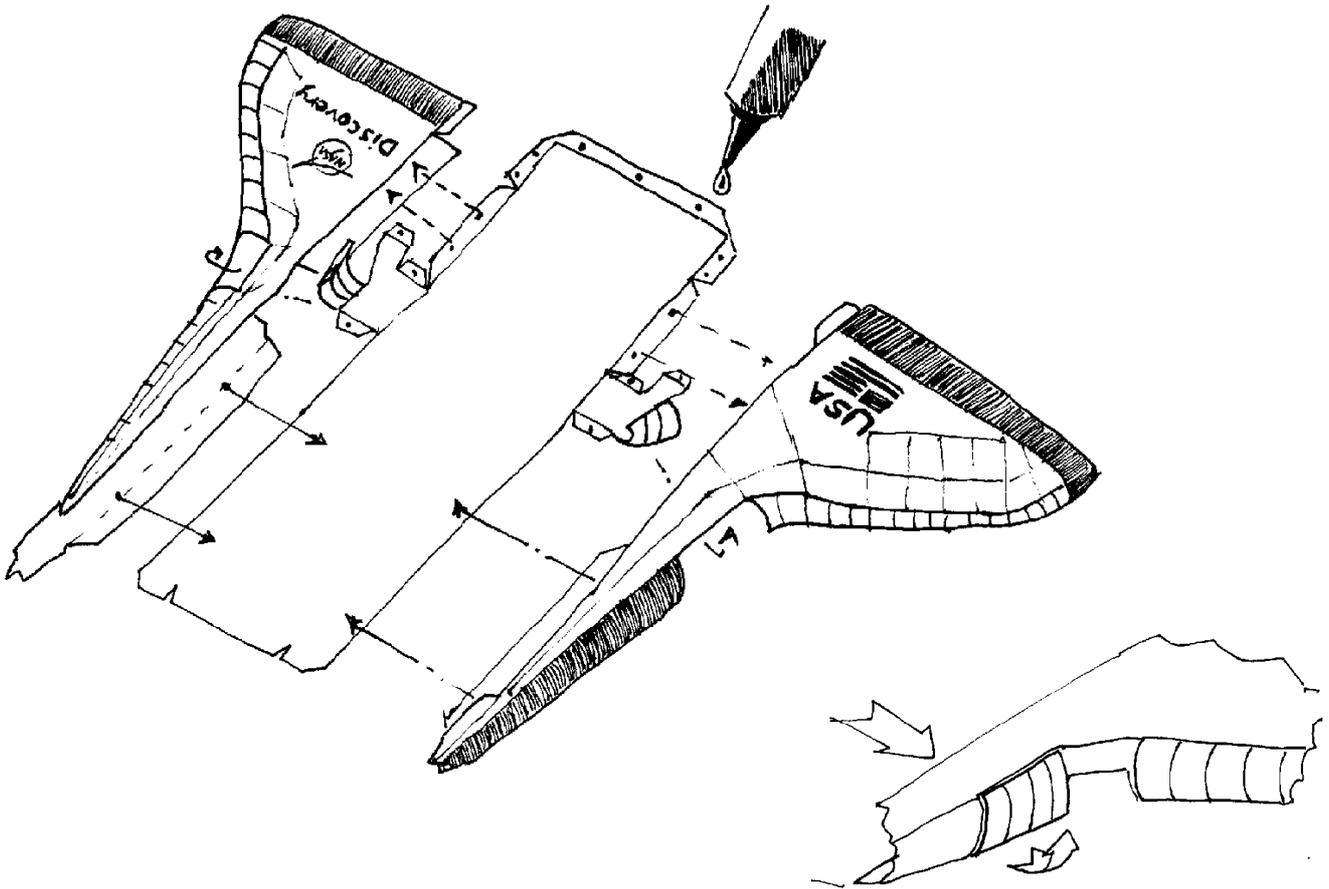

Glue the left and right wing to the orbiter under surface 4-1. Once it is dried, glue the gluing table 6-2,6-4 and 6-5 on the right wing in the open slot. Bend the additional leading edge Reinforced Carbon-Carbon (RCC) panel parts included in the 4-1 piece and glue them on the gluing tabs. Glue the tab 6-3 on the back of the leading edges panel once it is attached to the wing. Glue on the tabs the additional RCC Panel part 6-7 on the open slot. Repeat the procedure with the similar part of the left wing right wing and the 7-7 on the left wing.

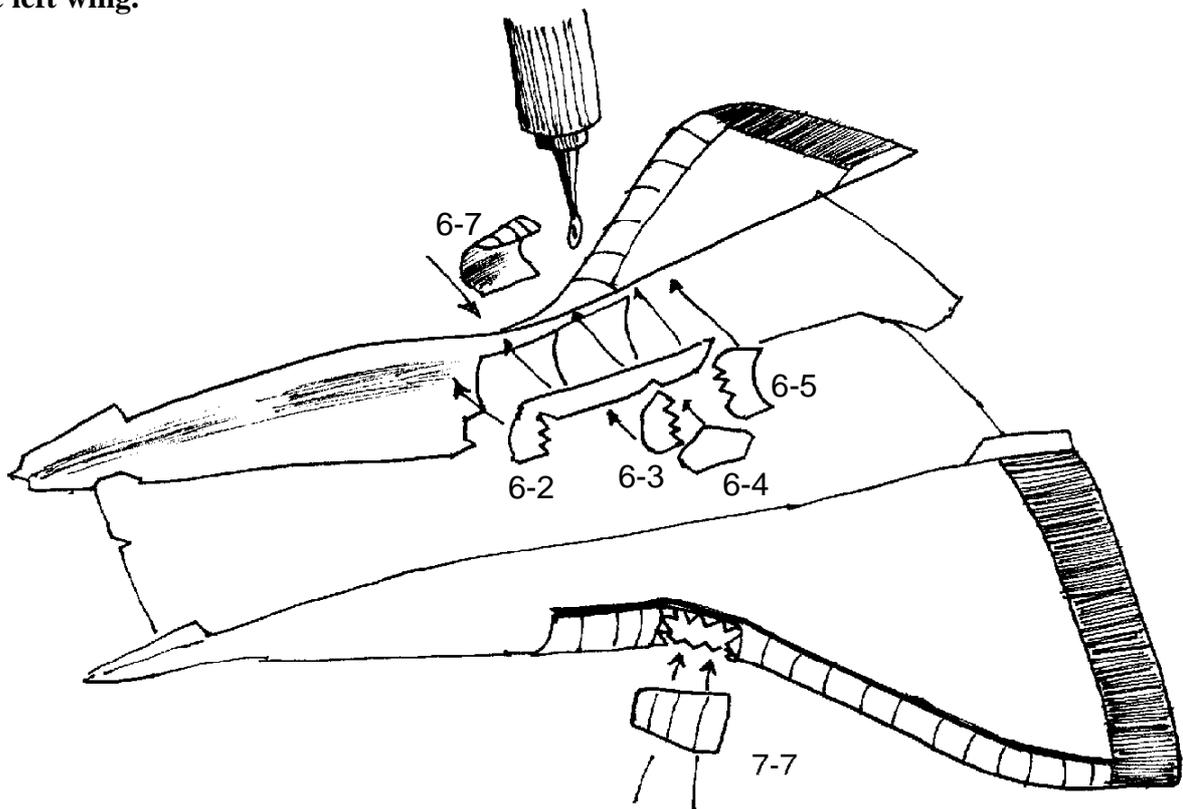

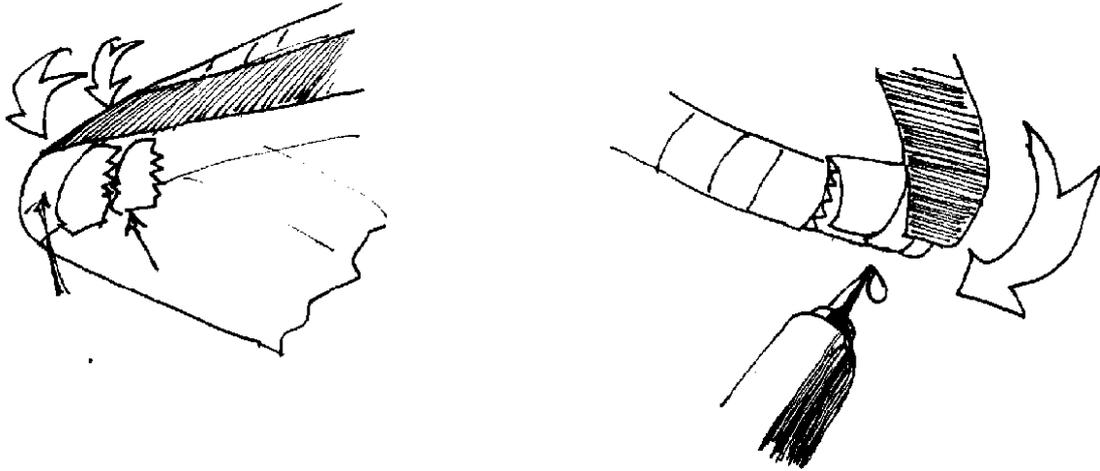

Glue the gluing table 6-23 and 6-24 on the back of the RCC panels at the wing tips. Bend the panel and close the wing tip by gluing the tab on the lower wing surface. The black wing tip will be glued later on.

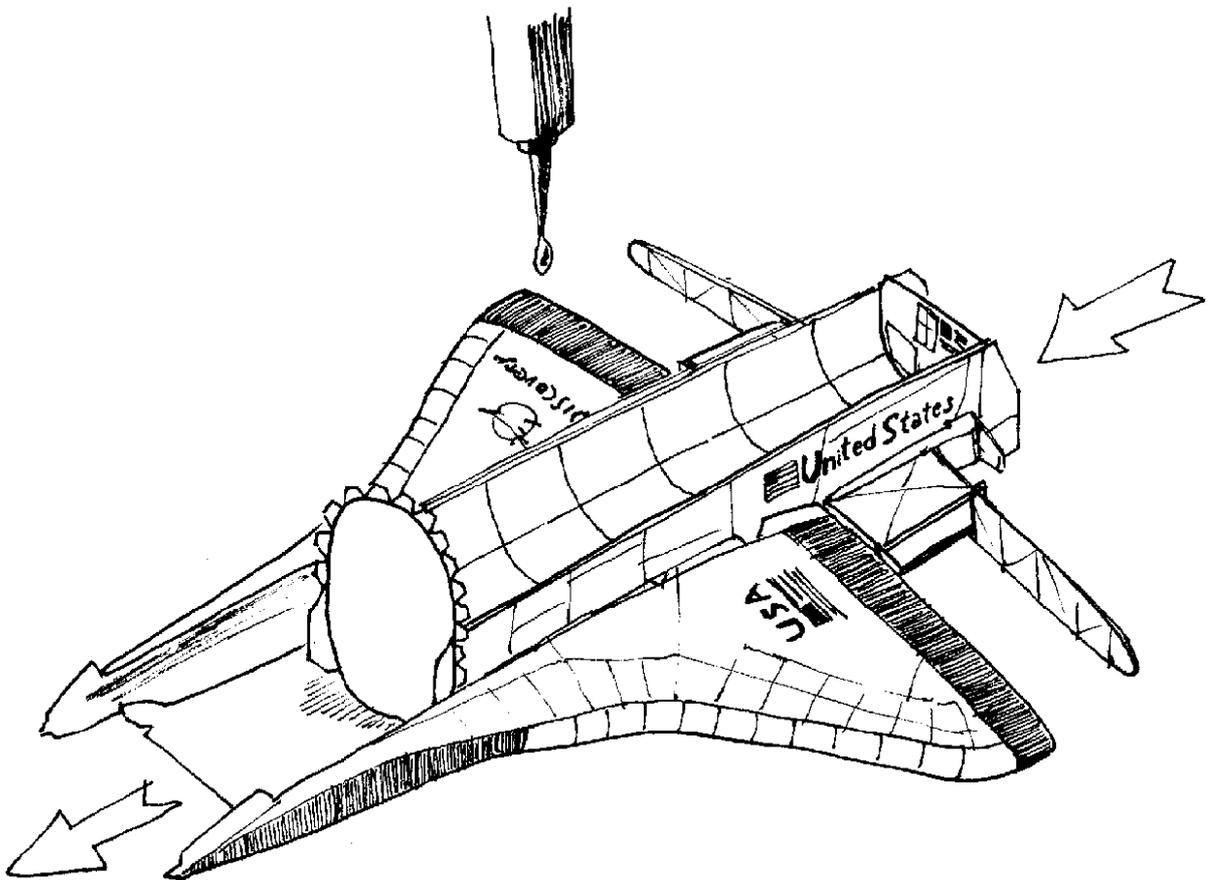

Try to bend both wings in the right shape by leaving weights on them during an entire night. Once the wings stay closed without weight, then insert the cargo bay sliding it from the back side. Glue the wings on the cargo bay tabs. Apply some glue also on the edges of the wing internal structure.

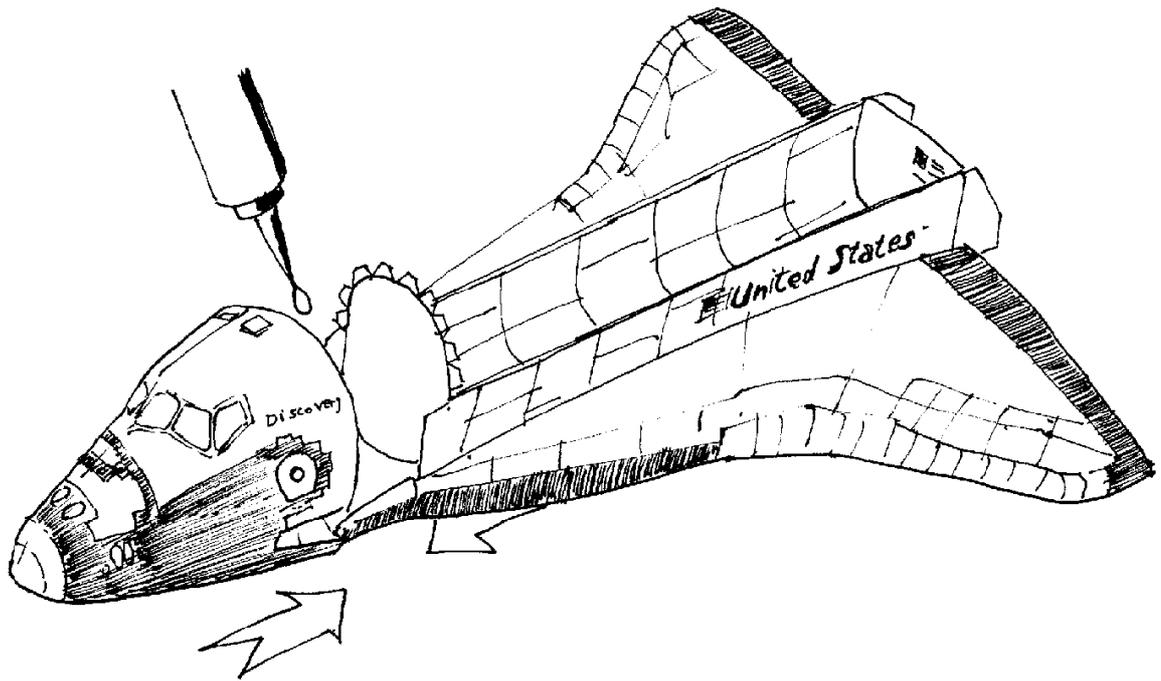

Once the cargo bay and the wings are attached, insert the orbiter fore part and glue it. Try the matching between the part without glue and adjust the tabs before applying the glue.

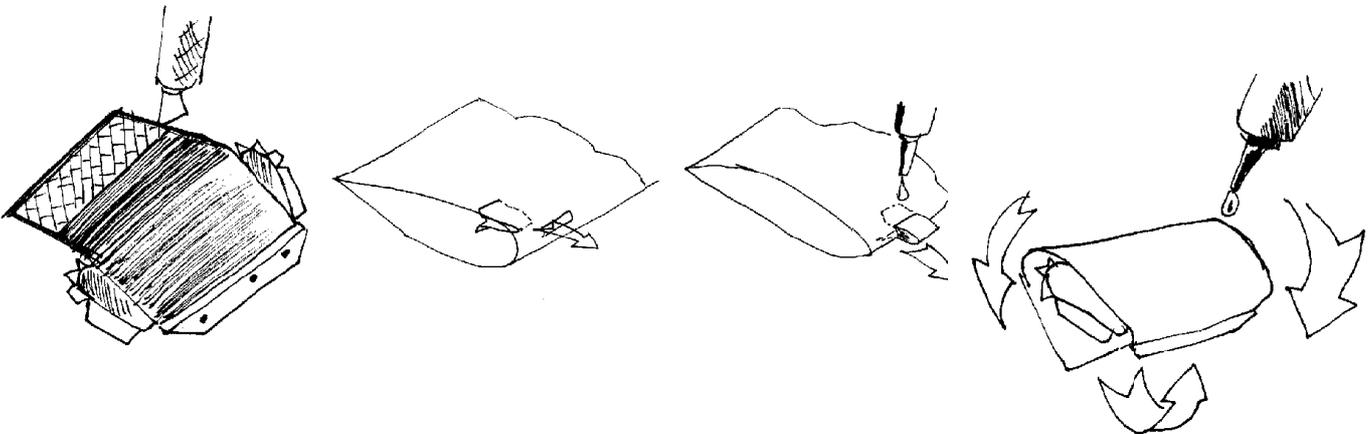

Cut the four elevons 5-10 & 5-11 and the body flap (5-8). Bend and fold them. Cut the hinges 5-9 for the elevons, 5-6 and 5-7 for the body flap. The 5-9, 5-6 and 5-7 have to pass through the slots and glued internally. Once dried, put the glue on the tabs and closes the elevons and flap.

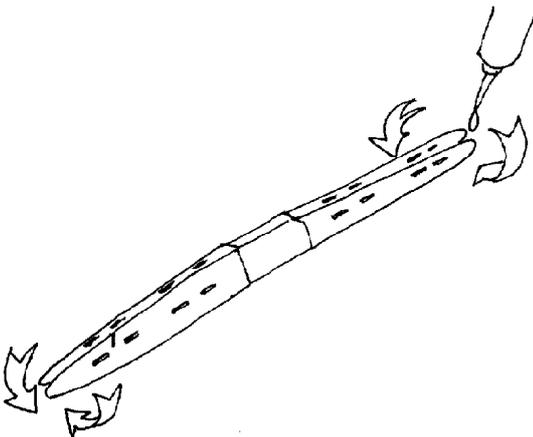

Cut the wings end spar 8-4, fold it and glue the two parts together. Cut the slots for the elevon hinges.

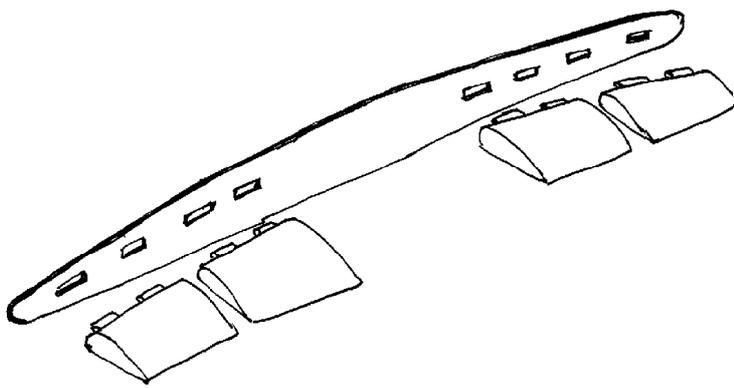

Insert the four elevon in the spar and glue them on the spar. You can also fix them to the spar by introducing a small paper roll inside the hinges once inserted into the slot

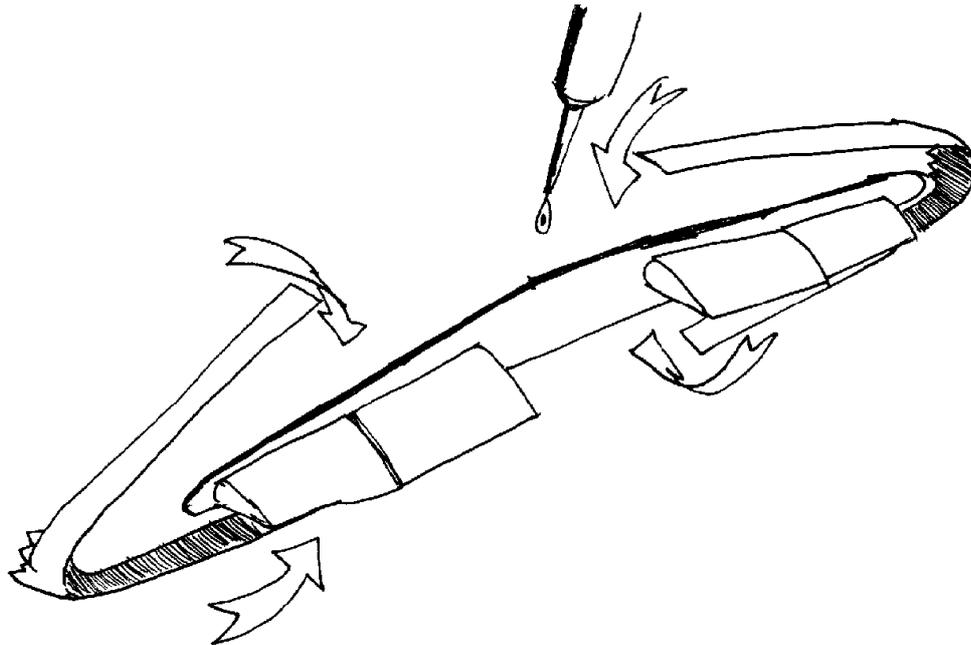
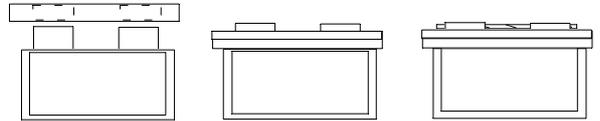

Cut and bend the 6-25 and 7-25. Glue the spar inside it as illustrated. The spar has to be aligned on the center line. Glue the spar on the painted side, so that the unpainted side stay outside.

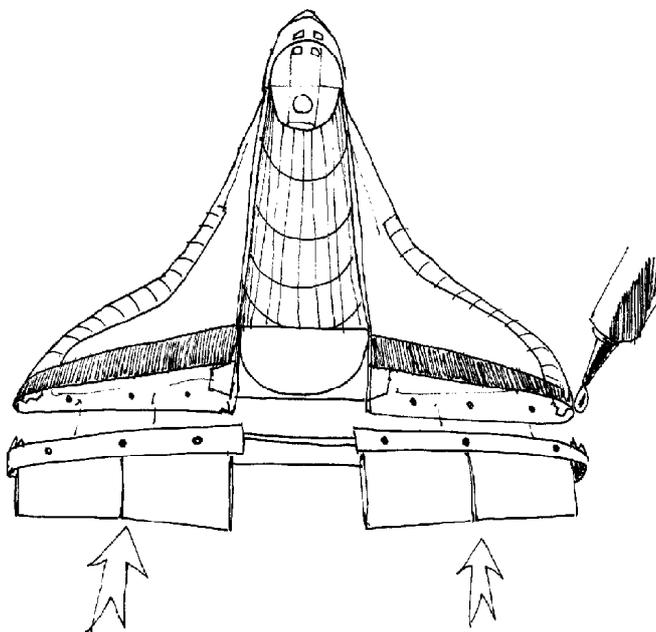

Once it is dried glue the part inside the wing. The spar has to be glued to the cargo-bay lower structure. The gluing tab at the tip are used to glue the black tip of the wings.

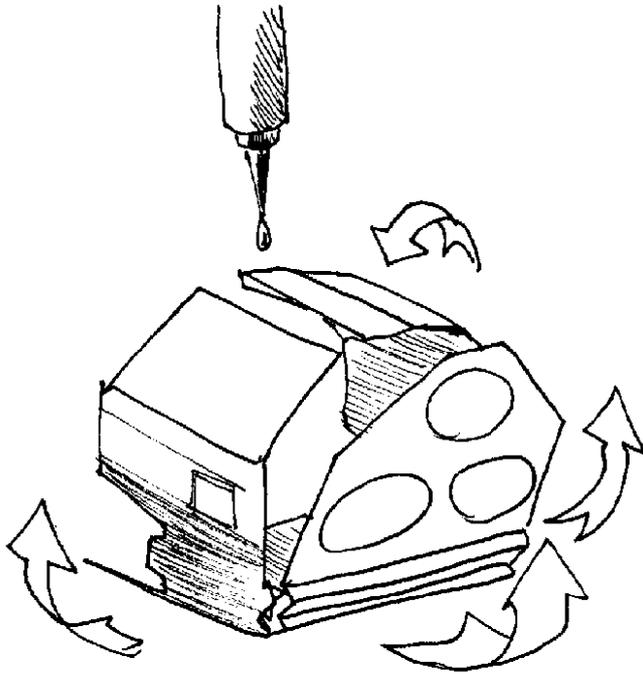

Cut the 8-1 Shuttle engine block and fold it. Fold it carefully with the step used to attach the body flap. Cut the slot and insert the body flap 5-8 already prepared. Put the glue on the gluing tab and close the structure.

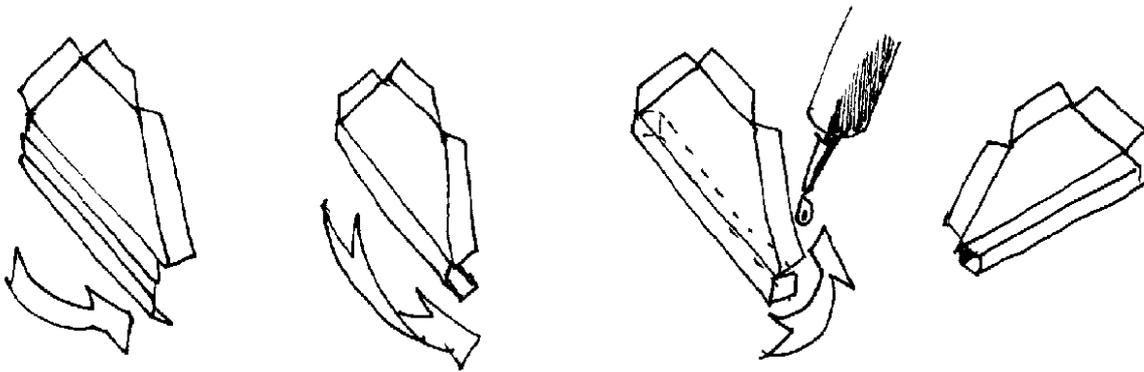

Cut the 8-2 upper part of the aft cargo bay wall. Fold the box spar located in the bottom part of it. Glue it inside the shuttle Engine block.

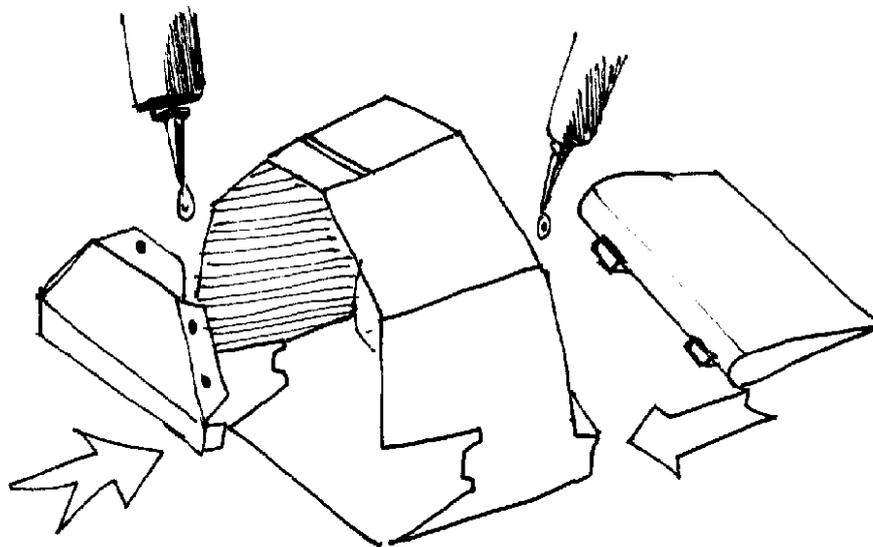

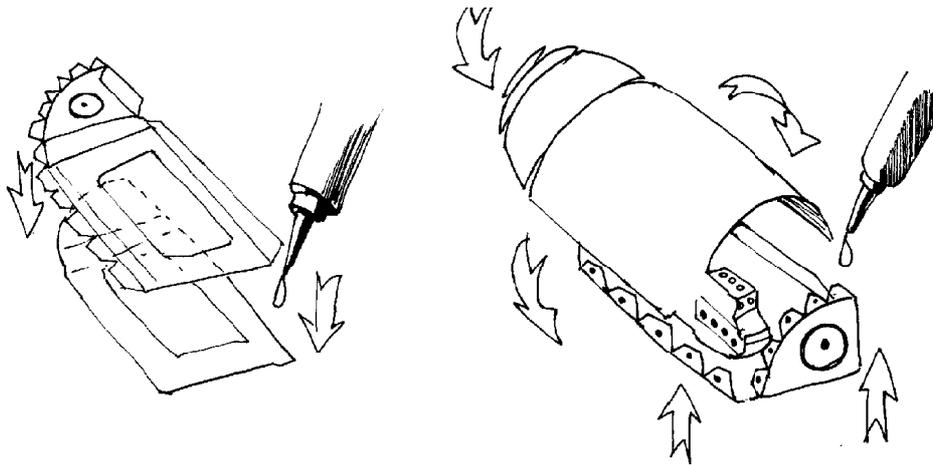

Cut the 8-5 and 8-6 in cardboard and attach them to the 6-17 and 7-17 for a more stiffness. These part represent the base for the Orbital Maneuvering System (OMS) pods. Cut the pods 6-8 and 7-8 bend them and fold the Reaction Control System (RCS) part. Use the gluing tabs 6-9-6-10, 6-11 6-12 and 6-13 for the right pod and the equivalent for the left pod to glue the part in the correct shape. Once the shape is correct glue each pod on its base.

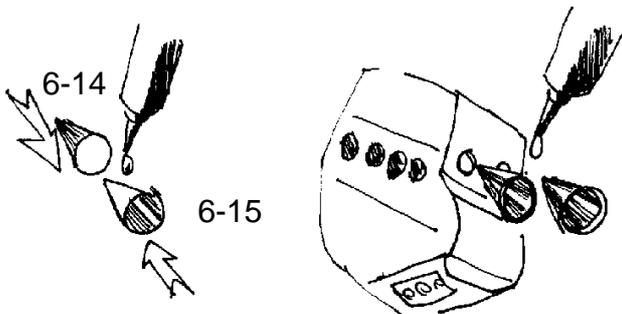

If you want you can cut the holes for the vernier thruster and insert the nozzles 6-16 and 7-16 inside the RCV part. 6-15 and 6-14 are mounted outside to form the two external nozzle of RCS

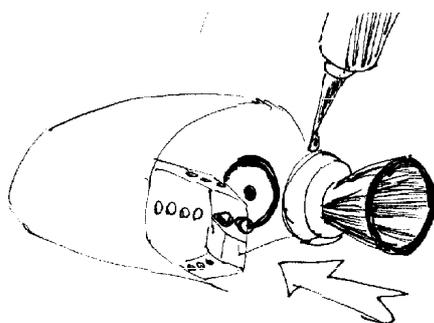
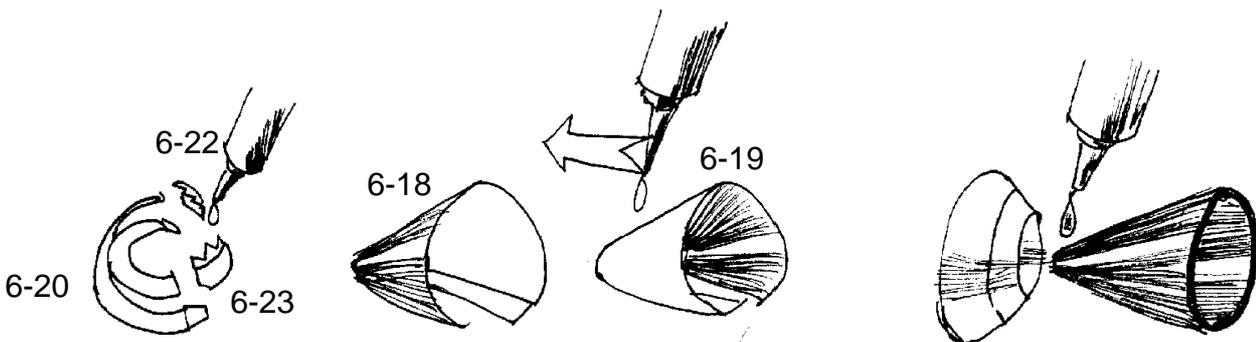

Mount the OMS right engine starting from the gimbal 6-20. Bend and glue it using the 6-22 and 6-23 tabs. Glue the 6-18 (external nozzle) and 6-19 (internal nozzle) together. Leave the hole at the center of the nozzle so that the injectors are visible through it. Glue the nozzle inside the gimbal and then glue it to the OMS pod. Repeat the sequence for the left OMS pod.

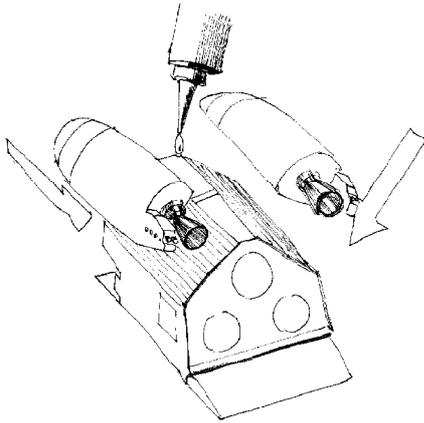

Glue the two OMS pods to the engine block.

Cut, bend and fold the two vertical rudders 5-12 (Left) and 5-13 (Right). Cut and fold the two hinges that have to be mount externally as indicated in the picture 5-5 lower and 5-6 upper. Check that the two rudders can be moved independently. Once glued, paint the back side of the hinges black. Attach the hinges to the vertical spar 8-3 as already illustrate. Glue the triangular parts 5-2 and 5-3 as upper and lower closure of the vertical stabilizer.

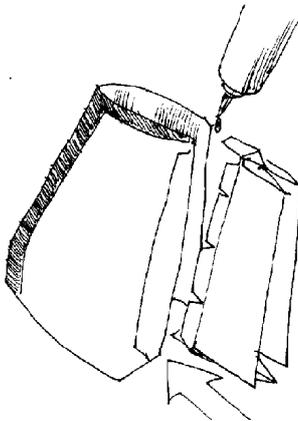
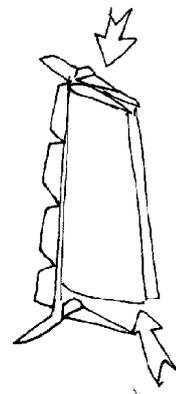
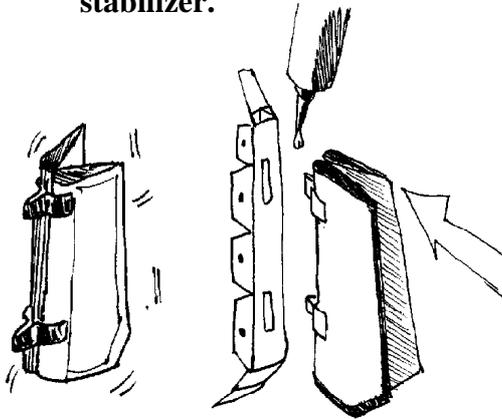
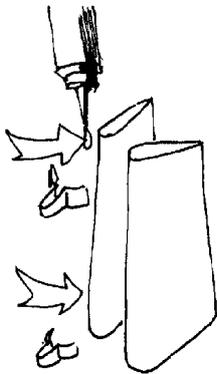

Cut, bend and fold the vertical stabilizer 5-1. Insert the spar with rudders and close it with glue. Check that a large gluing tab has to protrude from the bottom part.

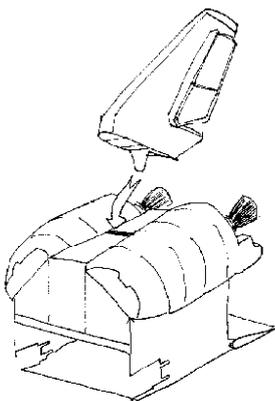

Cut the slot in the upper part of the engine rear block. Glue the red dot marked area and insert the gluing tab of the vertical stabilizer in the slot. Fold and glue the tab inside the rear engine block.

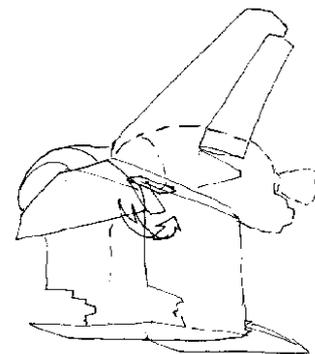

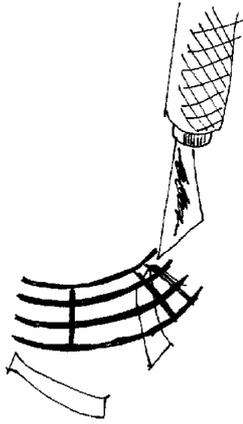

Cut the external pipes 9-5 of the three Space Shuttle Main Engines (SSME). Remove carefully the white parts between the gray lines (cooling pipes). Try to paint gray the cut edge so that the white line does not appear.

Cut the three nozzles 9-2 and the related gluing tabs (9-3 and 9-4). Bend the paper and form the external bell. Do the same with the internal part 9-1 and glue-it internally. Bend the cooling pipes and glue them externally to the nozzle.

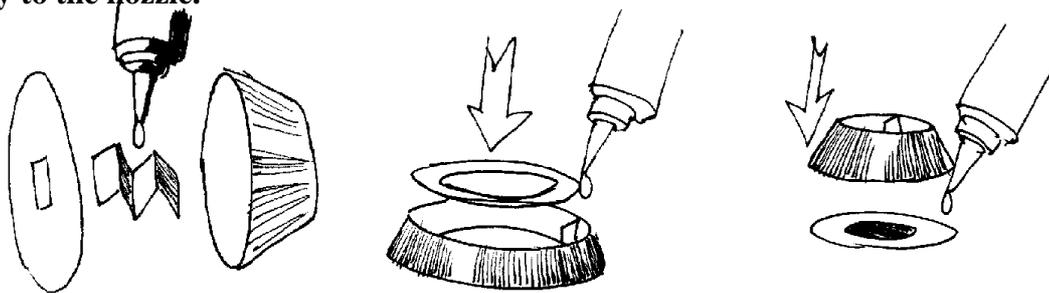
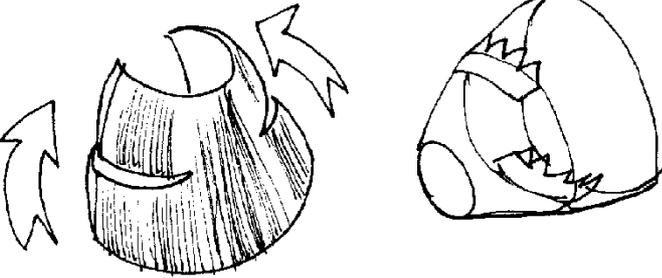

Cut the engine base 9-9, the paper spring 9-6 and the insulator ring 9-8. If the paper you used to print the model is very light then glue the base 9-9 and the injector 9-7 on a cardboard sheet and cut them together. Fold the spring as illustrated and glue it on the base. Roll the engine gimbal 9-11 and glue it with the insulator ring 9-8. Roll the internal engine gimbal 9-10 and glue it in the injector plate 9-7. Glue the 9-7 on the spring and close the mechanism with the external gimbal assembly gluing it on the edge of the engine base. Insert and glue the nozzle assembly. Once assembled the nozzle should have some degree of freedom and can be tilted a little bit.

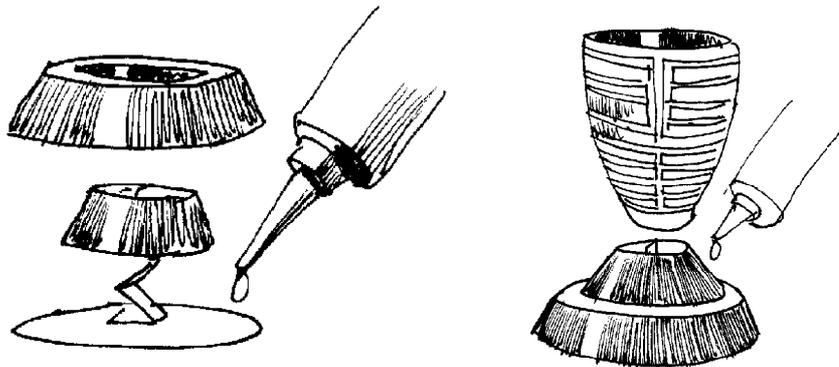

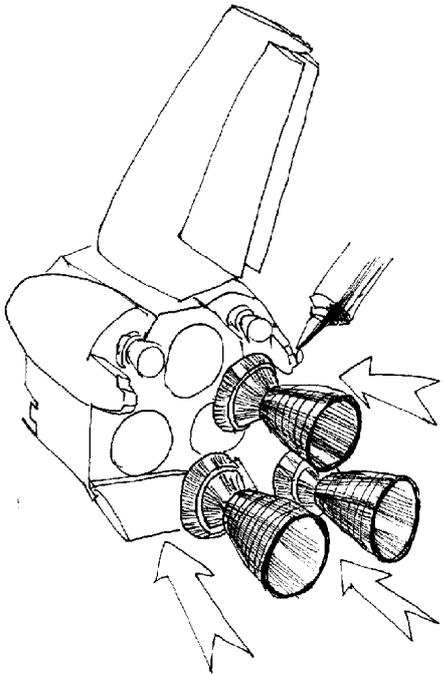

Glue the three engines on the back of the the Shuttle engine block.

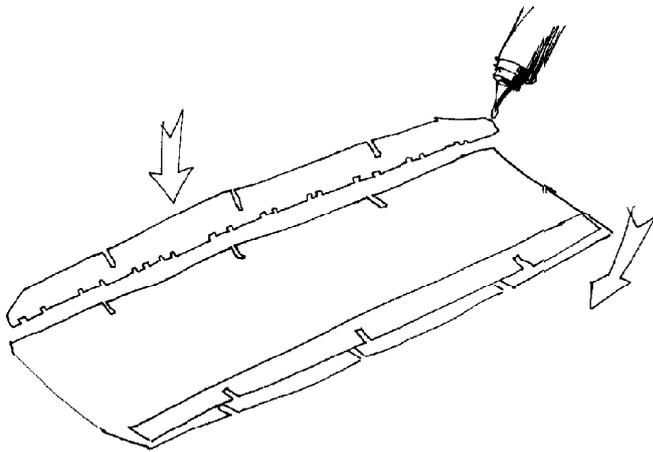

Start with right Thermal Radiator. Cut the radiator 10-5 and the two pieces 10-6 and 10-4 that serve to increase the thickness of the part. Glue them on the back side of radiator 10-5. Cut the three lateral slots carefully on both part. Before to bend cut all the slots for the astronauts handles (the small white boxes on the left edge of the radiator 10-5).

Start to fold the radiator so that the painted gray part is the part on the lower surface.

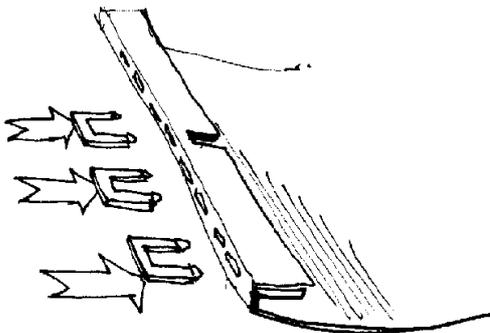
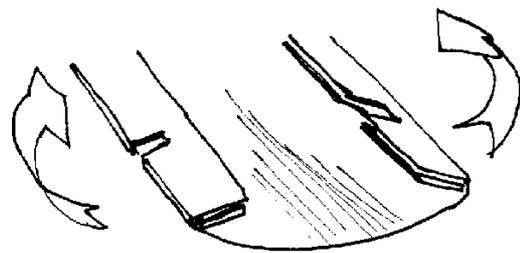

Cut each handle 10-7 fold on the center-line and glue it. Insert each handle in the relative slot (the one corresponding on the right side on the handle). Glue each handle and when you finish glue the back side of part 10-6 on the unpainted part of radiator.

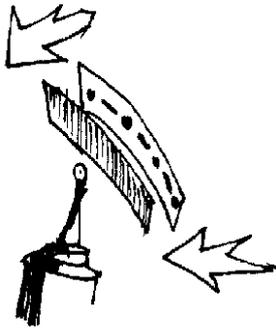

Cut and glue the parts 10-8 and 10-9 one by one (so that each part is the same from both side.

Glue the 10-9 on the three internal slots and the 10-8 on both ends.

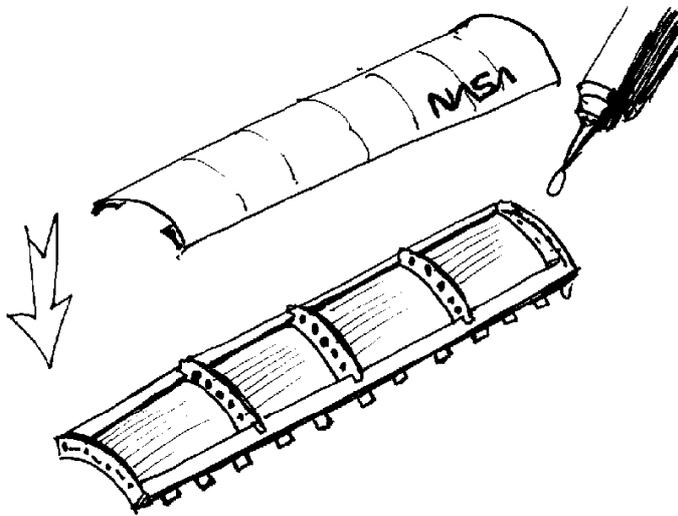
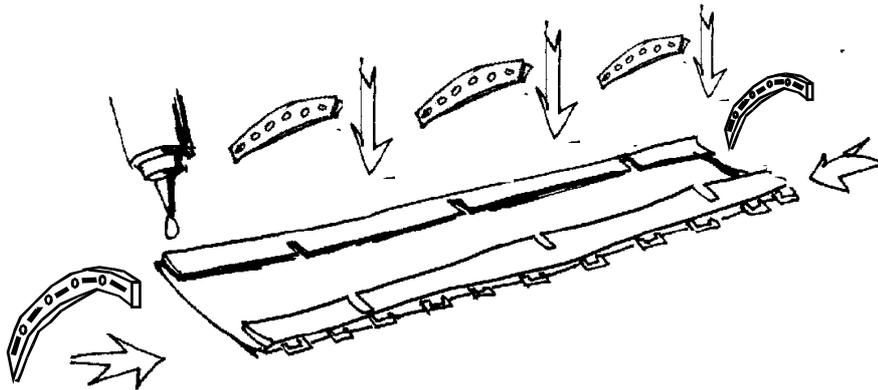

Repeat the similar procedure with the cargo bay door 10-1 and the parts 10-2 and 10-.

At the end glue the door on the radiator.

Repeat the assembly with the left Radiator-cargo bay door.

Cut, fold and glue the three hinges of the cargo bay doors.

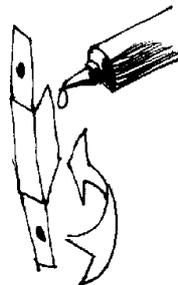

Glue them on the marked boxes and attach the doors to the cargo bay.

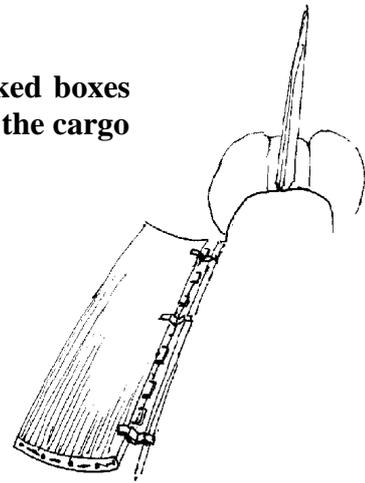
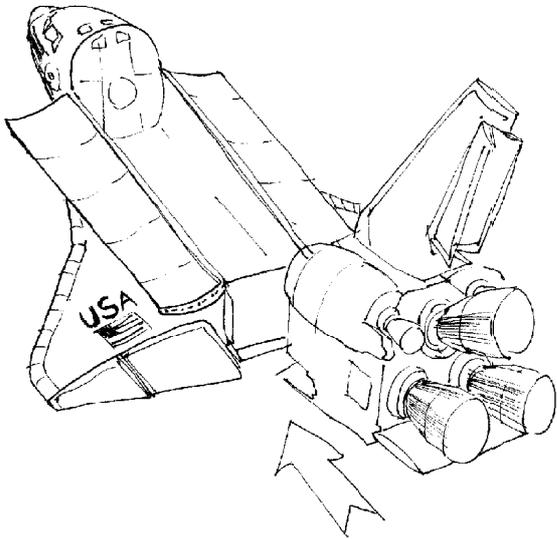

Insert and glue the shuttle motor block to the model.

SHUTTLE CARGO BAY SUB-SYSTEMS

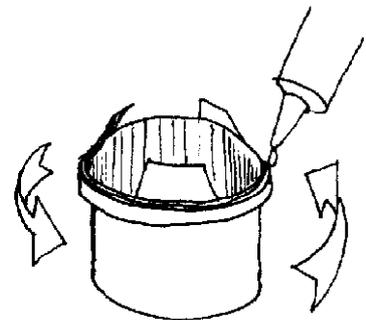
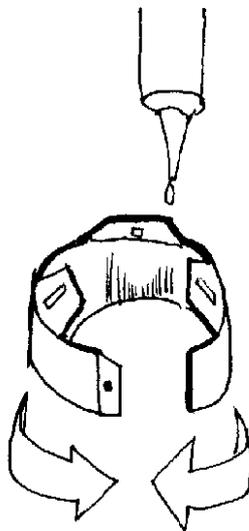
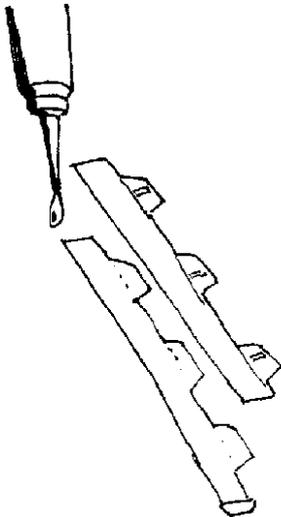

Cut the two parts of the shuttle-ISS hatch 12-45 and 12-46. Bend them on a sharp edge. The 12-46 yellow wall is the internal side. Once the circular shape has been achieved, glue them together and attach the gluing tab internally so that the yellow wall cover completely the tab. Cut the 12-35 thin stripe and glue it around the hatch as indicated in the right drawing.

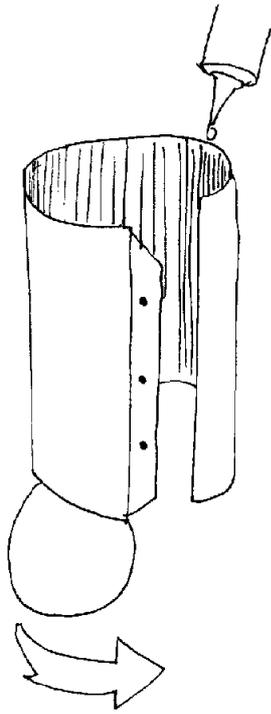

Cut the pressurized vertical tunnel 12-54. Roll it on a sharp edge and glue it forming a tube. Bend the lower "cap" and glue it through the tabs.

Insert the hatch from above and glue it. Cut the connectors ring 12-6 and glue it in the space from the hatch and the external tube.

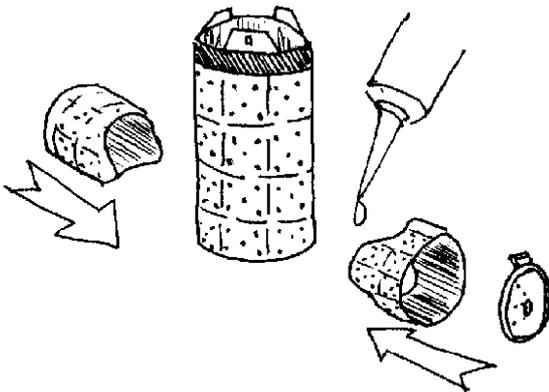
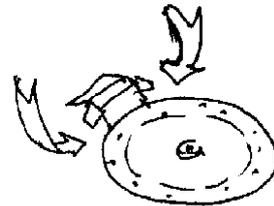
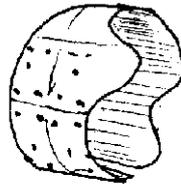
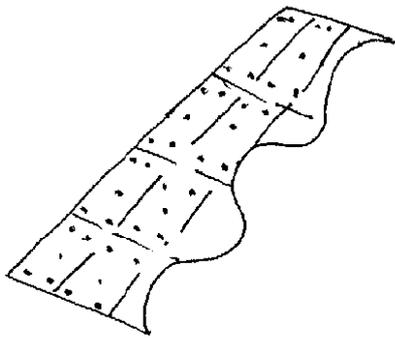
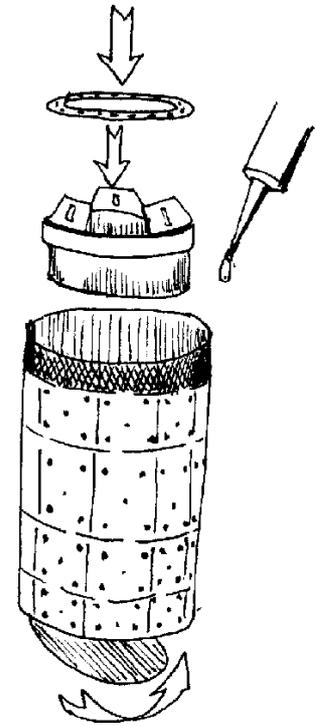

Cut the tube 12-47, roll it and form a tube. Glue it on the back side of the vertical tube in the circular area located on the gluing line.

Cut the hatch 12-33 and bend the small elements attached to it to form a small box. Cut the short tube 12-50, roll it and glue it. Glue the hatch on the flat part of the 12-50 tube. Glue the saddle-shaped side on the vertical tube on the circular area below the two black spots.

Cut the horizontal tube 12-38, roll it and form a tube. Cut the cone 12-34 and form a shroud. Glue the shroud on the 12-34 tube using the gluing tabs. The horizontal tube has to be mounted so that the circular area is located exactly on the upper side. Also the handles on the shroud should be located on the upper side once glued.

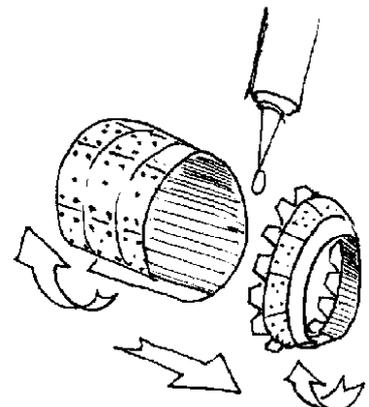

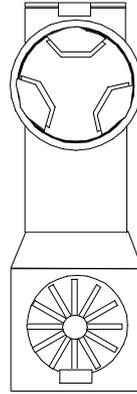
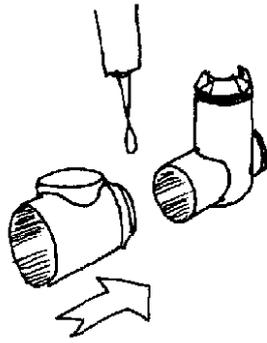
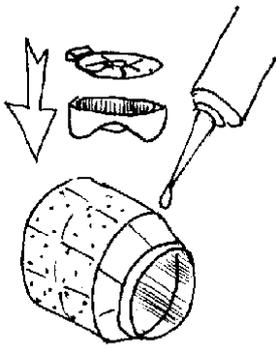

Cut the hatch 12-19 and bend the small elements attached to it to form a small box. Cut the short tube 12-51, roll it and glue it. Glue the hatch on the flat part of the 12-51 tube. Glue the saddle-shaped side on the horizontal tube on the circular area. The shape of the cargo bay tunnel is depicted in the sketch illustrated above on the right side.

Cut the two parts 12-52 and 12-55. Bend on the lines to form two rectangular-section structures. Do the same with the 12-49 part that is a longer strut. Cut the 12-56 and form a structure with rectangular-section as indicated in the sketch illustrated below that can be used as mounting reference.

The parts 12-11, 12-12, 12-13, 12-14, 12-15 and 12-16 are tubes used as struts in the hatch-tunnel locking structure. The tubes have to be cut at the right length once in place. The parts 12-9 and 12-10 represent the fixation panels on the cargo bay.

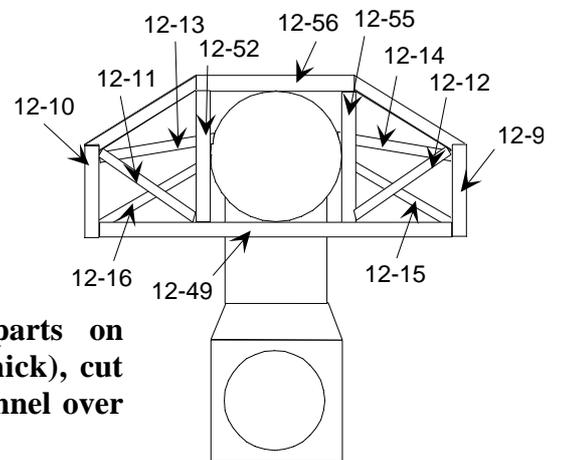
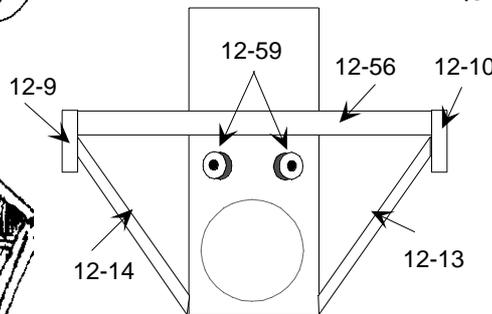
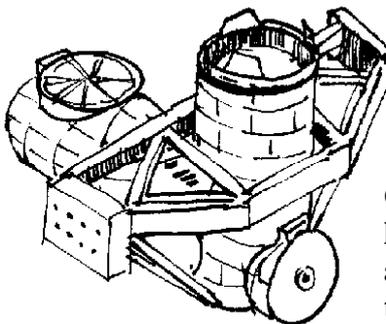
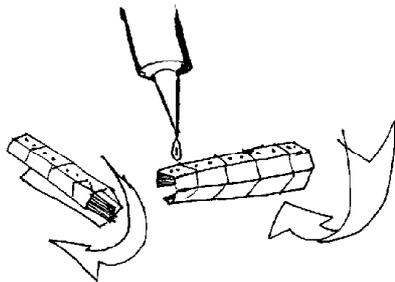
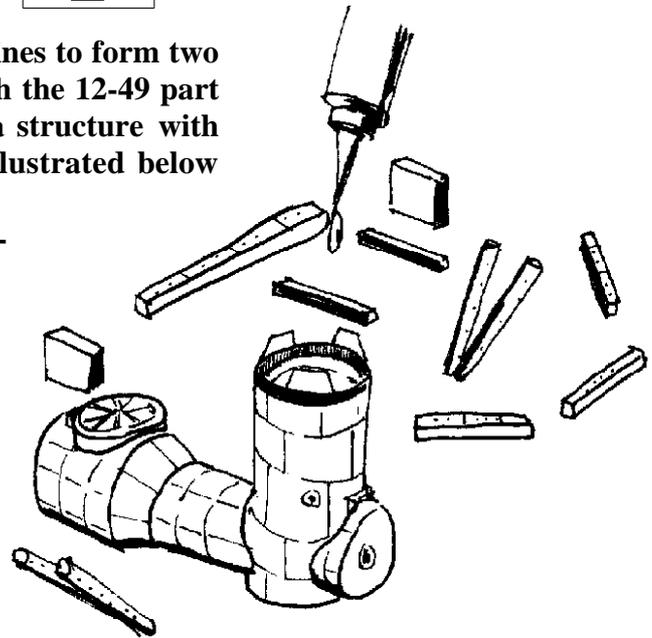

Once completed glue the 12-59 parts on heavy cardboard (0.7-1.0 mm thick), cut and glue them on the vertical tunnel over the already marked spots.

Insert the ISS tunnel and hatch in the cargo bay and glue it. The glue has to be placed on the two hatch attachment located on the wall of cargo bay and on the crew compartment wall.

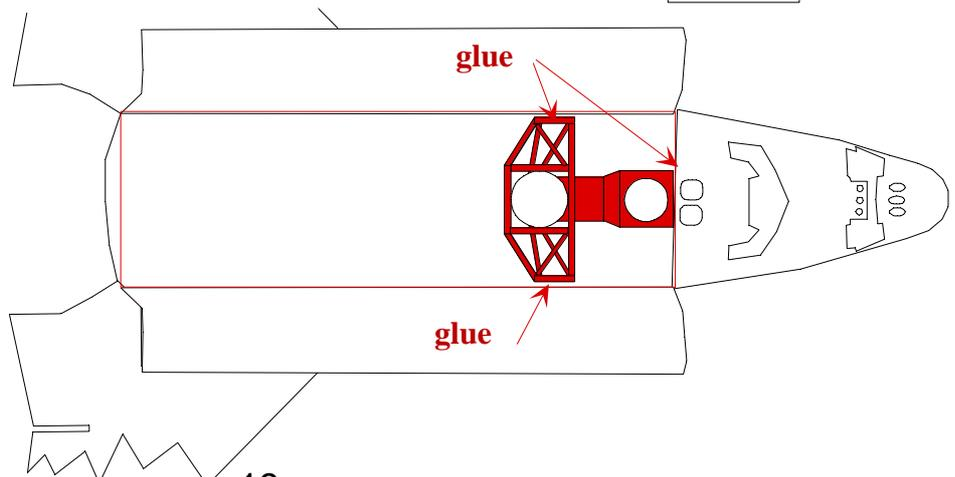

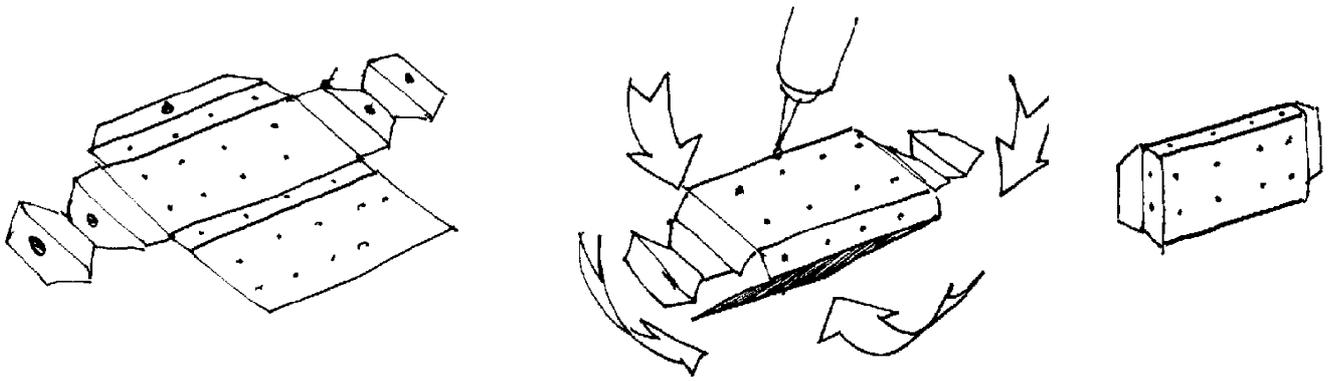

Cut the parts 12-1, 12-2, 12-3, 12-4 and 12-5. They are the panels used to lock Get Away Special (GAS) containers and electronic boxes to the cargo bay. Bend the parts to form a box with two flat lateral appendices used to attach it to the cargo bay attachment points.

Once the five boxes have been mounted cut the two electronic boxes 12-43 and 12-44 and glue on one of the panels as indicated below in the sketch a).

Cut the GAS container 12-36 together with its electronic boxes. This GAS is equipped with an opening lid so that it has a small box mounted on a side containing the related mechanism. Glue the GAS and the electronic box as indicated in the sketch b).

Cut the two GAS containers 12-39 and 12-40. Roll them on a sharp edge and glue as a cylinder. Bend the upper and lower lids and glue them on the tube. These GAS's are mounted on the same panel. Glue the GAS's as indicated in the sketch c).

Cut the GAS container 12-48 together with its electronic boxes 12-41. Glue the GAS and the electronic box as indicated in the sketch d).

Cut the IMAX container 12-37. Bend it an form a box. Glue the IMAX as indicated in the sketch e).

Cut the two support panels 12-7 and 12-8. Mount them as flat boxes as indicated in the sketch f).

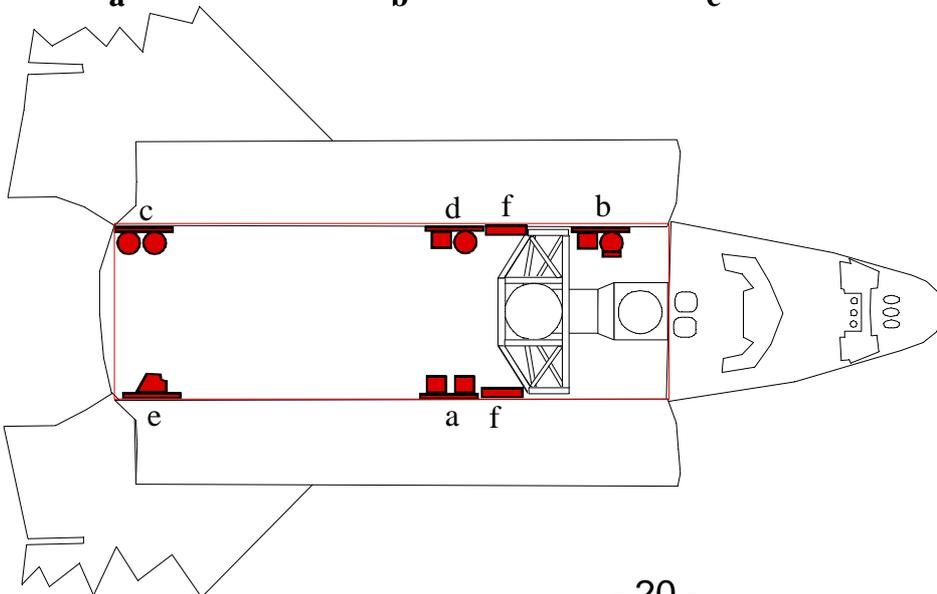
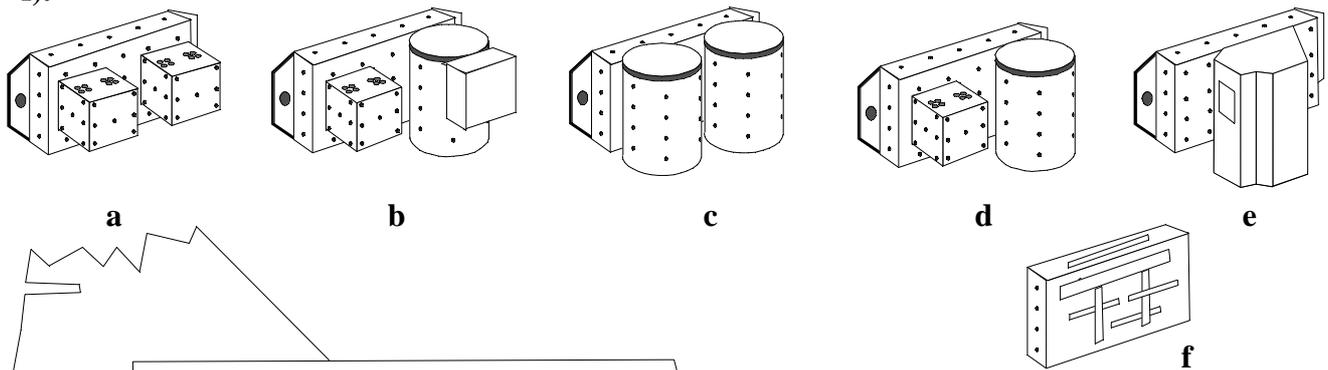

Glue the seven pallets at the locations indicated in the cargo bay by a white box with a red spot in the middle. On the page 3 of the ISS Model, around the cargo bay arrows and lables clarify the position of each subsystem.

In the left sketch is illustrated the rough position of each pallet.

Before to start the assembly of the Canadian robotic arm (Remote Manipulator System) cut the area containing the parts 12-21, 12-28, 12-23 12-22, 12-29 and 12-25 and glue it on a thick cardboard (around 0.5 mm).

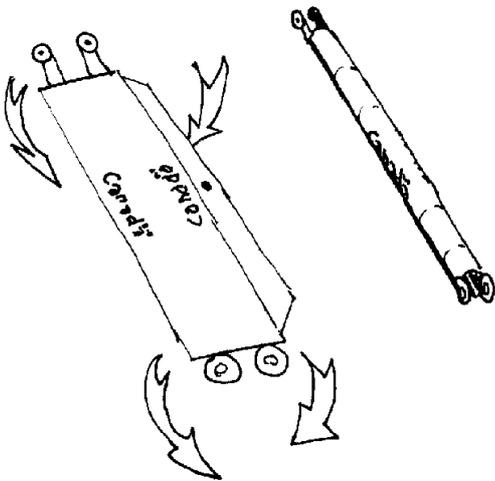

Cut the 12-26 arm and roll it. Pay attention on the shoulder and elbow hinges that should be kept flat. Increase the strength of the hinges by gluing them on the cardboard (only the hinges not the tube). Glue the tube inserting a pen refill or a wooden stick inside to keep the circular section.

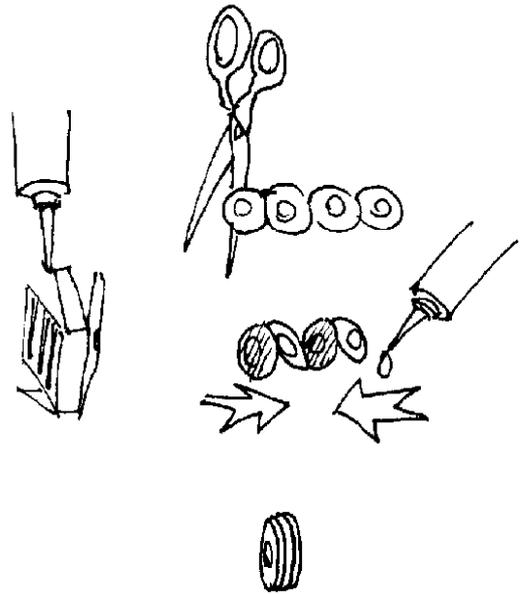

Cut the box 12-31 and mount it. Cut the horizontal bearing 12-25, bend it and glue the disks together to form a thick disk. Insert a pin into the disk and in the box. The pin ensures the shoulder yaw motion. Cut the shoulder pitch hinge 12-24. Bend it and glue it. Bend the lower flaps horizontally and glue them on the horizontal bearing. Don't spread the glue on the box to avoid to stack the rotating mechanism. The different assembling phases are illustrated below.

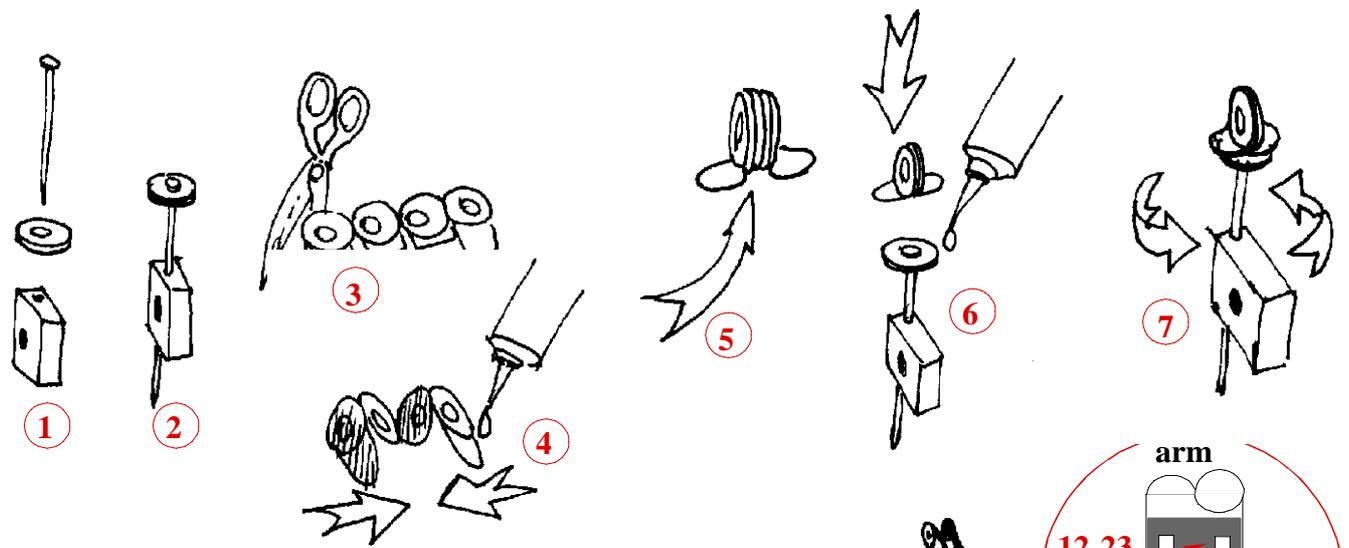

Insert the reinforced 12-23 hinges in the arm shoulder and glue them in place.

Insert the arm on the shoulder yaw box and fix it by using a second pin to ensure the shoulder pitch mechanism. Trim both pins by cutting them just outside the hinges

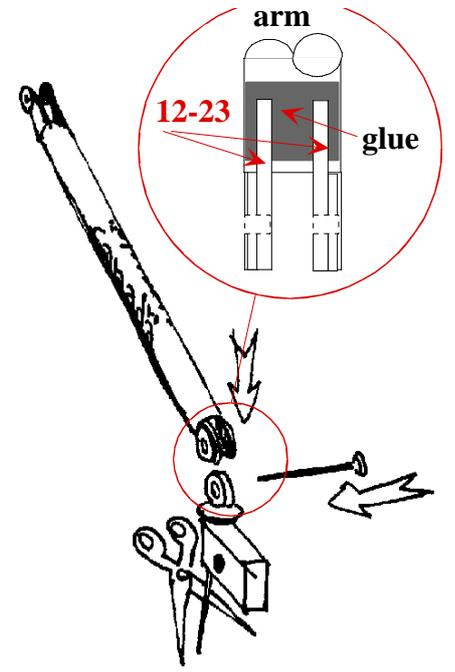
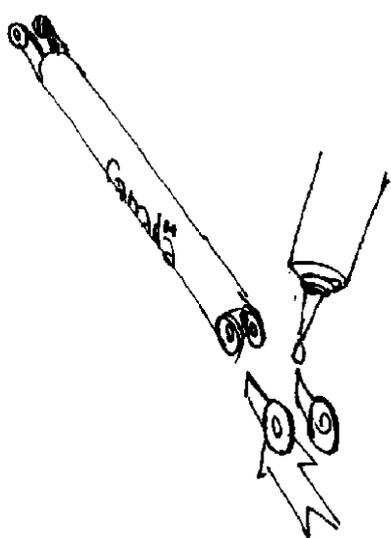

Cut and roll the arm part 12-27 as you did for the 12-26. Glue it as a tube. Cut the elbow hinge 12-21 part, bend it and glue it. Once the glue is dry insert it in the tube through the side marked with e box. Glue it in place so that it is symmetric respect to the other part of the hinge located on the other tube of the arm. The box indicate the top side while the hinge is glued as indicated in the sketch below. Roll as a spiral one the stripes 12-57. Roll one the two 12-58 parts around the spiral and insert the it inside the tube gluing in place

Joint the two elbow parts and fix them by using a third pin to ensure the elbow pitch mechanism. Trim the pin by cutting them just outside the hinges

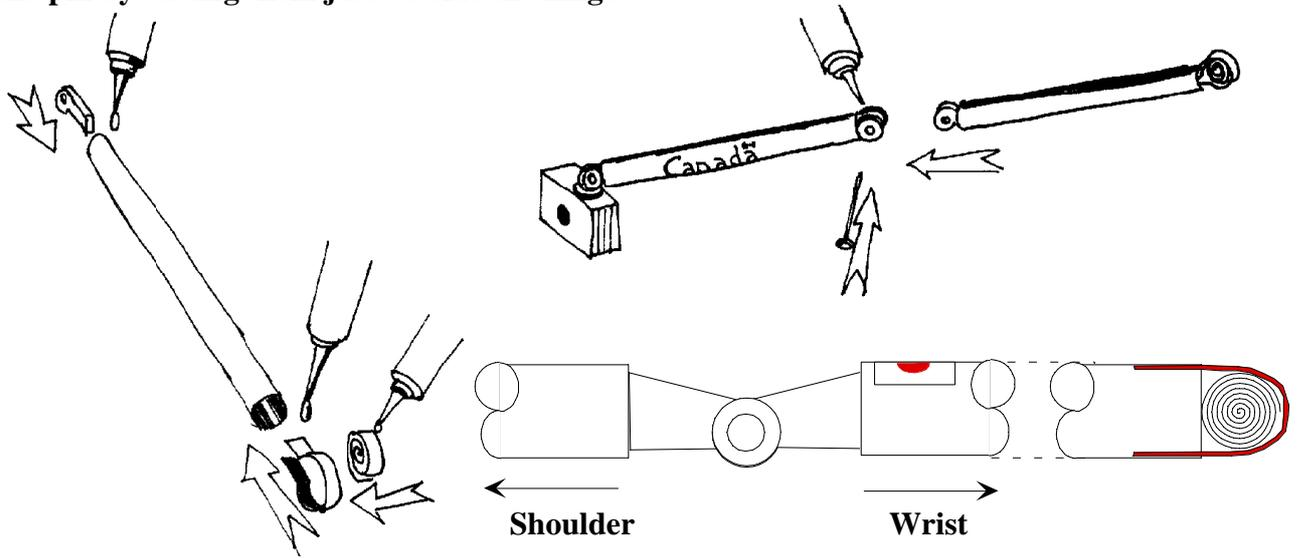

Cut and mount the small squared box 12-29. Glue it as a cube. Cut the wrist hinge 12-28 part, that should be reinforced with thick cardboard. Bend it and glue it on the small cube. Roll as a spiral the second stripe 12-57. Cut the 12-18 arm grapple and form a tube. Roll the last 12-58 parts around the spiral and insert it inside the grapple tube gluing in place. Be aware that the spiral has to be mounted horizontally in the grapple to ensure the wrist yaw rotation while the other spiral is used for the wrist pitch. The grapple top is indicated by the gluing box.

Joint the two wrist parts and fix them by using two pins to ensure the wrist pitch and yaw mechanism. Trim the pins by cutting them just outside the hinges. Put a small amount of fast glue on the four pins to fix them in place. Cover the pin heads with white corrector liquid

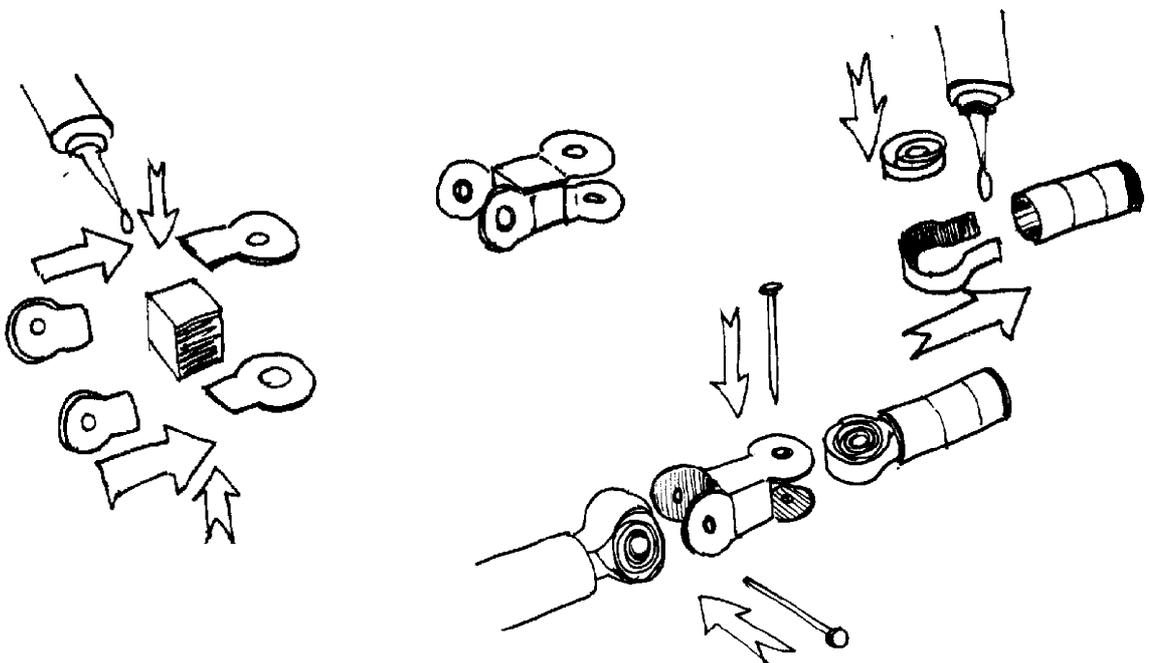

Cut and mount the external camera 12-17. It is a very small box. The black dot on a small side represents the lens and indicate the camera front side. Mount the camera on the arm grapple.

Cut and mount the external camera 12-20. It is a formed by two boxes connected by two supports. The black dot on a small side of the upper box represents the lens and indicate the camera front side. Mount the camera on the arm gluing box located close the elbow.

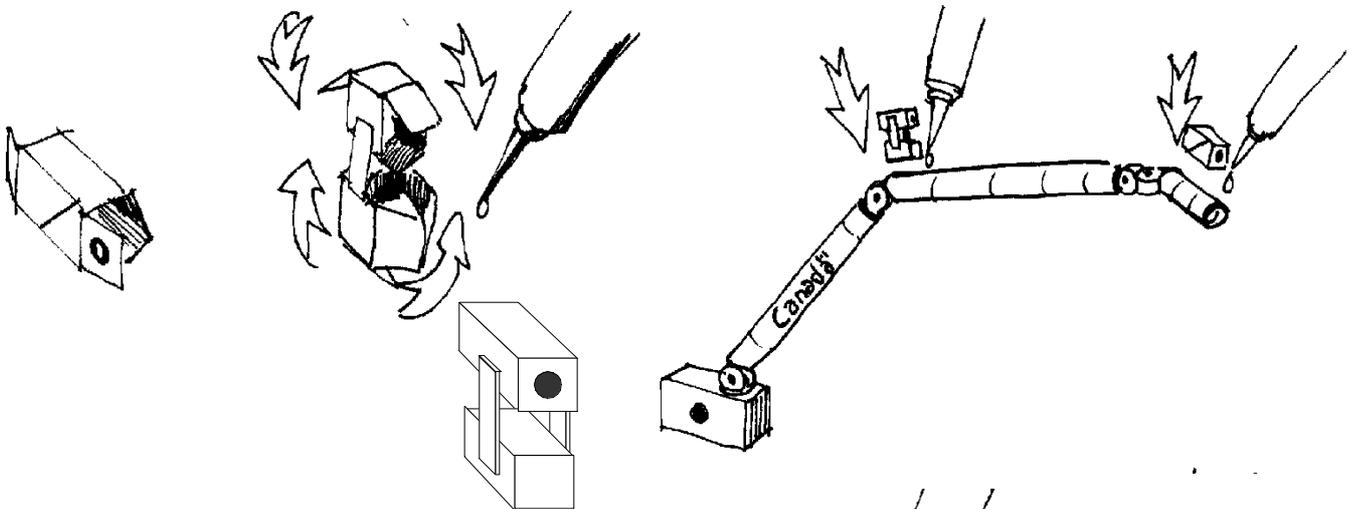

Cut and mount the three arm holders or supports 12-35. Look the images below to understand how to bend and glue them. Once the glue is dry glue them to the cargo bay side wall.

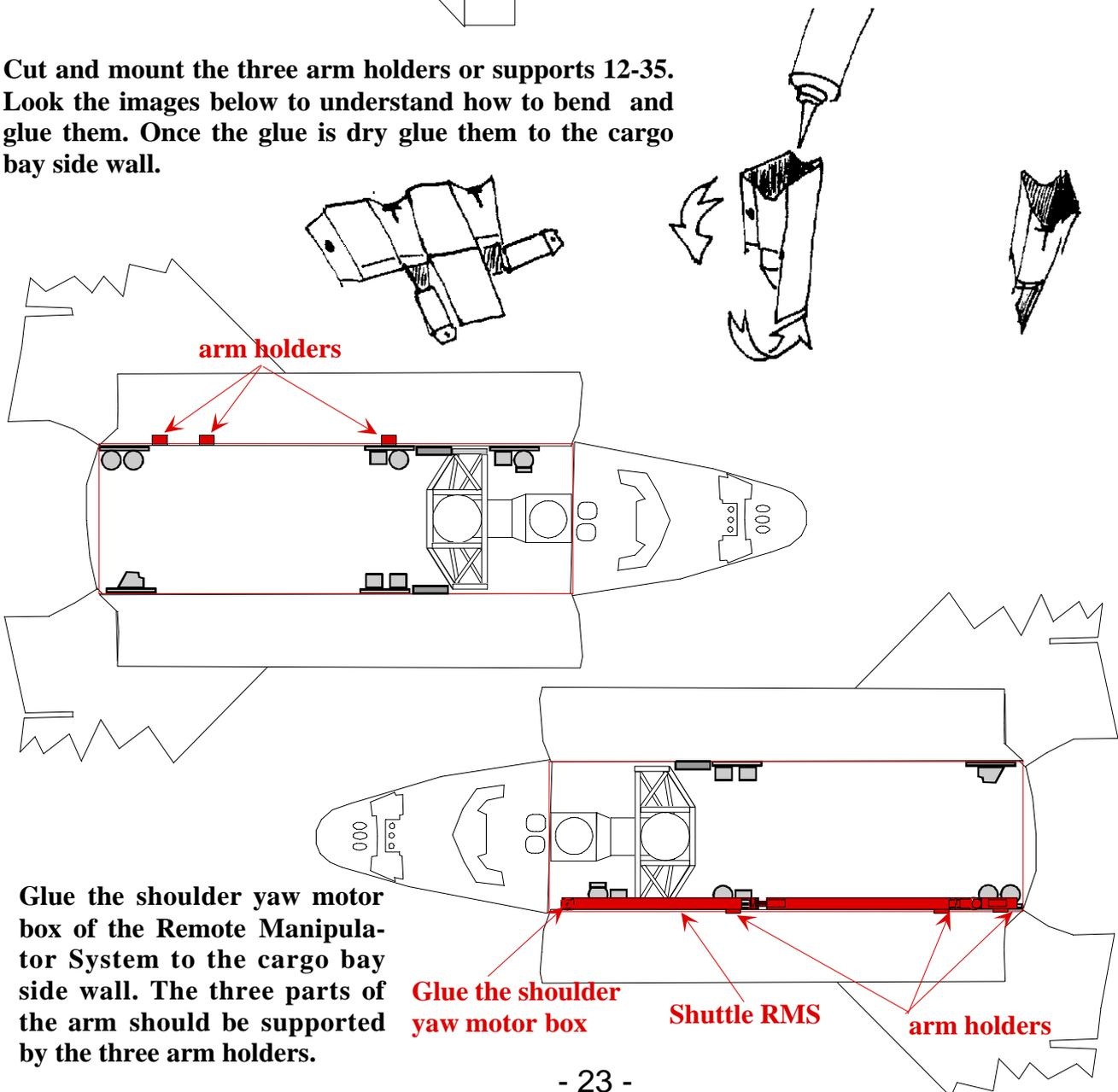

Glue the shoulder yaw motor box of the Remote Manipulator System to the cargo bay side wall. The three parts of the arm should be supported by the three arm holders.

Glue the shoulder yaw motor box

Shuttle RMS

arm holders

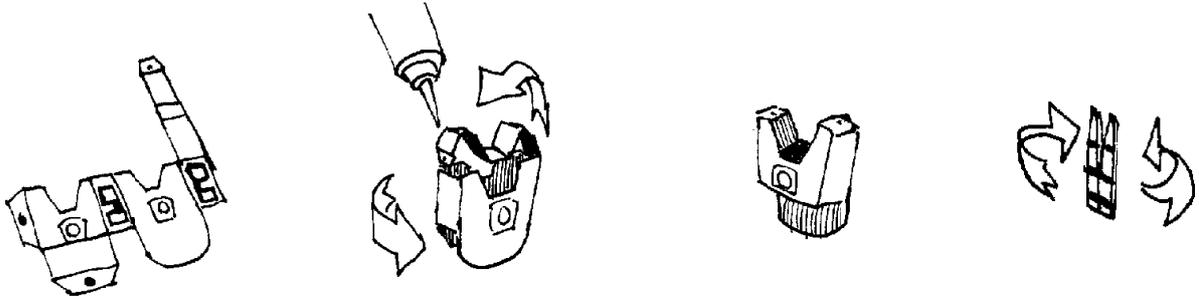

Cut and mount the four Unity attachment point 12-17. Mount the box as illustrated above. Cut the small yellow-black striped guides, bend them and glue two of them on each locking device.

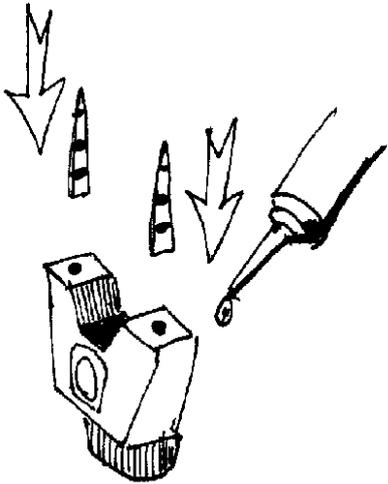

Look the sketch beside to understand how to bend and glue them. Once the glue is dry fix them to the cargo bay side wall with a small drop of glue.

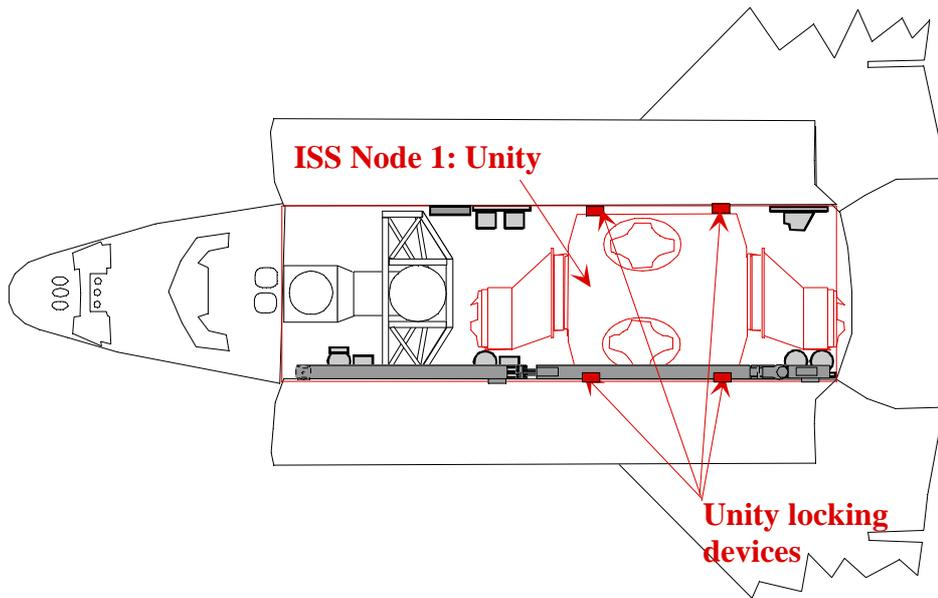
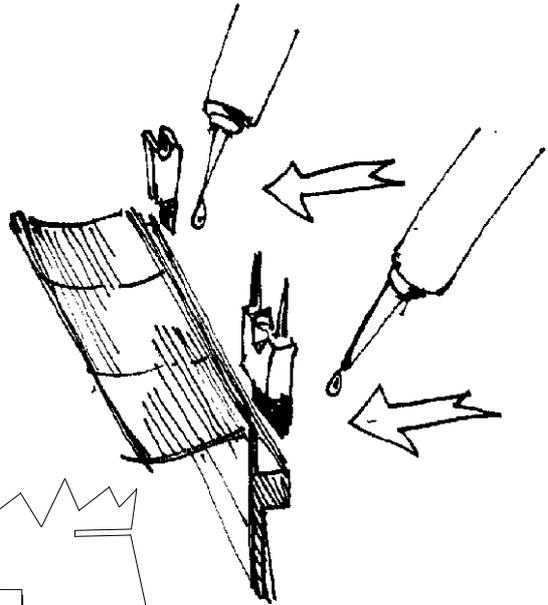

If you want you can include in the cargo bay also a Model of Unity that was the main payload of the STS-88 flight. To improve the realism you can use four parts of a metallic pin as fixation rod that have to be inserted in the Unity locking mechanism

Congratulation, you finished !!

If you enjoyed and if you like your new Shuttle Model, why don't joint the ISS Paper Model Supporter group by providing a financial help to the designer? Please send your contribution in your national currency in a closed envelop directly to:

**Raimondo Fortezza
Via A. Falcone, 58
I-80127 Naples
Italy**